

SOUTH DAKOTA DEPARTMENT OF
ENVIRONMENT & NATURAL RESOURCES
PROTECTING SOUTH DAKOTA'S TOMORROW...TODAY!

**Underground Storage Tank Systems:
Owner and Operator Guide**



DENR
SOUTH DAKOTA

This handbook provides general guidance for the operation and maintenance of regulated underground storage tank systems.

For specific requirements refer to the underground storage tank rules
Administrative Rules of South Dakota Chapter 74:56:01
<https://sdlegislature.gov/Rules> <https://denr.sd.gov/tanks>

Table of Contents

South Dakota’s Underground Storage Tank Program.....	04
Underground Storage Tanks.....	04
Plans and Specifications.....	05
2018 Changes for Installation Requirements.....	05
Notification Requirements.....	05
Notification of Underground Storage Tank Form.....	06
Change or Ownership Notification Form.....	11
Alternative Fuel Compatibility Form.....	12
Leak Detection.....	14
Certification.....	14
Automatic Tank Monitoring.....	15
Automatic Tank Gauge Operational Testing Form.....	16
Secondary Containment with Interstitial Monitoring.....	17
Statistical Inventory Reconciliation.....	17
Vapor Monitoring.....	18
Groundwater Monitoring.....	19
Manual Tank Gauging.....	19
Manual Tank Gauging with Tank Tightness Testing.....	20
Manual Tank Gauging Records.....	21
Table of Test Standards for Manual Tank Gauging.....	21
Inventory Control with Tank Tightness Testing.....	22
Monthly Inventory Record.....	23
Leak Detection for Product Piping.....	24
Release Detection Requirements for Suction Piping.....	24
Release Detection Requirements for Pressurized Piping.....	25
Automatic Line Leak Detection.....	25
Line Tightness Testing.....	26
Interstitial Monitoring with Liquid Sump Sensors.....	26
Containment Sump Testing Form.....	28
Spill and Overfill Prevention.....	29
Spill Prevention.....	29
Spill Prevention Equipment Testing Form.....	30
Overfill Prevention.....	31
Overfill Prevention Equipment Testing Form.....	32
Cathodic Protection.....	33
Galvanic (Sacrificial) Cathodic Protection.....	33
Impressed Current Cathodic Protection.....	34
Internal Lining.....	34

Cathodic Protection Testing Form.....	36
Underground Storage Tank Operator Training.....	40
Class A Operators.....	40
Class B Operators.....	40
Class C Operators.....	40
Class C Operator Training Certificate.....	41
Walk-Through Inspections.....	42
Monthly Walk-Through Inspections.....	42
Annual Walk-Through Inspections.....	42
Walk-Through Inspection Checklist.....	43
Leak Response and Reporting.....	45
Airport Hydrant and Field Constructed Systems.....	46
Underground Storage Tank Closure.....	47
Regulated Storage Tank Removal Notification Form.....	48

South Dakota's Underground Storage Tank Program

Underground Storage Tanks

In 1984, the United States Congress passed laws regulating certain classes of underground storage tanks (USTs). The Environmental Protection Agency (EPA) subsequently delegated authority of this program to the individual states. South Dakota began regulating underground storage tanks in 1987, with the adoption of the Administrative Rules of South Dakota (ARSD) Chapter 74:56:01. The South Dakota Department of Environment and Natural Resources (DENR) Storage Tank Program is responsible for enforcing the UST rules while working closely with the regulated community, the public, and local, state, and federal agencies. The DENR performs compliance inspections of each regulated UST system at least once every three years.

An UST system, according to ARSD Chapter 74:56:01, is defined as any tank or combination of tanks, including the underground pipes connected to it, that is used to contain an accumulation of regulated substances, the volume of which, including the volume of the connected underground pipes, is 10 percent or more beneath the surface of the ground. The term does not include farm or residential USTs with capacities of 1,100 gallons or less used for the storage of motor fuel for non-commercial purposes and USTs used for the storage of heating oil for the consumptive use on the premises where stored.

Construction material of USTs include single and double walled fiberglass and steel, steel coated with fiberglass (composite), and steel jacketed in fiberglass. A typical single walled fiberglass UST system with commonly associated components is shown in the image below.

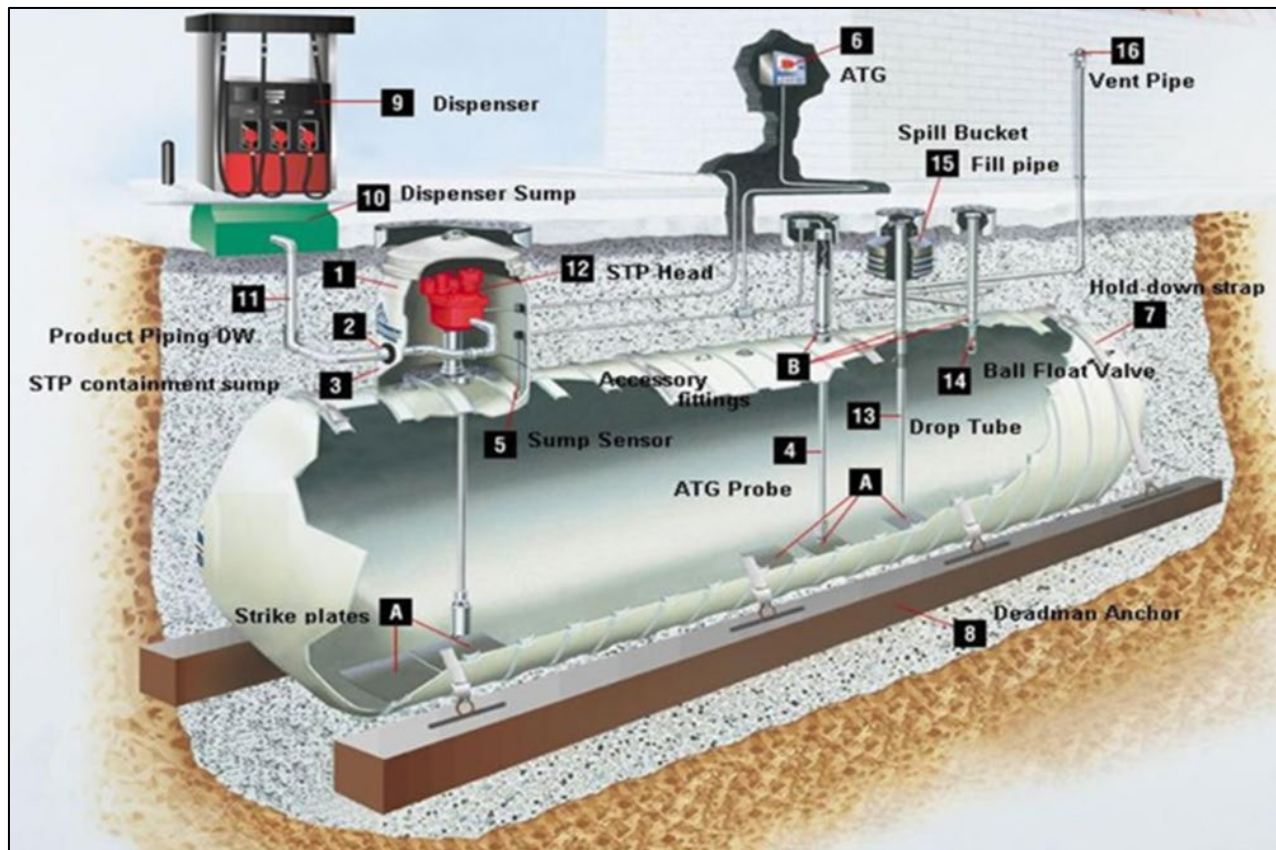

Plans and Specifications

To ensure new tank systems are installed according to state regulations and requirements, plans and specifications for proposed regulated UST systems must be submitted to the Ground Water Quality Program for review and approval at least 30 days before construction begins. If the submittal meets state requirements, the DENR will provide written approval to the UST system owner or operator. If insufficient information is submitted the DENR will request further information.

At a minimum, the plans and specifications for UST systems must include detailed information regarding the USTs, product lines, leak detection, spill and overfill prevention, and secondary containment. The plans must include all information relevant to show the tank system is in compliance with the state rules and must include a site map. Other state, federal, and local agencies, such as state and local fire prevention authorities, may also need to review and approve the plans.

2018 Changes for Installation Requirements

EPA recently released new installation requirements. Since South Dakota receives state program approval through EPA, the state was given three years to adopt the new requirements. As a result, UST systems installed after October 13, 2018 must meet the following requirements:

- All new UST system installations must have secondary containment and the ability to detect leaks.
- All new UST system installations must have spill containment, overfill protection, and protection from corrosion.
- All new product piping installations must be secondarily contained, must terminate in UST and under-dispenser sumps, and must include automatic line leak detectors and sump and interstitial sensors for leak detection.
- If over 50% of existing product piping is replaced after October 13, 2018, then the entire pipe run must have secondary containment, including UST, transition and under-dispenser sumps, automatic line leak detectors, and sump and interstitial sensors.

Notification Requirements

Notification of Underground Storage Tank Form - Upon completion of UST system installation or upgrade, a completed Notification of Underground Storage Tank form must be submitted to the DENR within 30 days. An example of a Notification of Underground Storage Tank Form is shown on page 6.

Change of Ownership Notification Form - Any person or entity who obtains ownership of a regulated UST system must notify the DENR within 30 days of acquisition by submitting a completed Change of Ownership Notification Form. A Change of Ownership Notification Form is shown on page 11.

Alternative Fuel Compatibility Form - Owners and operators must notify the department at least 30 days prior to switching to an alternative fuel containing greater than 10 percent ethanol and/or greater than 20 percent biodiesel by submitting a completed Alternative Fuel Compatibility Form to verify the compatibility of biofuels with the UST system. The Alternative Fuel Compatibility Form is shown on page 12.



Notification for Underground Storage Tanks

Ground Water Quality Program, Storage Tank Section 523 East Capitol, Pierre, SD 57501 Phone # (605) 773-3296, Fax # (605) 773-6035 denr.sd.gov/tanks			STATE USE ONLY		
			FACILITY ID NUMBER:		
			DENR P&S NUMBER:		
TYPE OF NOTIFICATION			DATE RECEIVED:		
<input type="checkbox"/> A. NEW	<input type="checkbox"/> B. AMENDED	<input type="checkbox"/> C. CLOSURE	A. Date Entered into Computer _____		
No. of tanks _____ at facility		No. of continuation sheets attached _____			
INSTRUCTIONS			B. Data Entry Clerk Initials _____		
Please <u>type or print in ink</u> all items. This form must be completed for each location containing underground storage tanks. If more than five (5) tanks are owned at this location, photocopy the following sheets, and staple continuation sheets to the form.			C. Owner was contacted to clarify responses, comments: _____ _____ _____		

GENERAL INFORMATION

Notification is required by Federal law as well as by the Administrative Rules of South Dakota (ARSD) Chapter 74:56:01:11, for all underground tanks that have been used to store regulated substances since January 1, 1974, that are in the ground as of May 8, 1986, or that are brought into use after May 8, 1986. The information requested is required by Section 9002 of the Resource Conservation and Recovery Act (RCRA), as amended.

The primary purpose of this notification program is to locate and evaluate underground tanks that store or have stored petroleum or hazardous substances. It is expected that the information you provide will be based on reasonably available records, or in the absence of such records, your knowledge, belief, or recollection.

Who Must Notify? Section 9002 of RCRA, as amended, requires that, unless exempted, owners of underground tanks that store regulated substances must notify designated State or local agencies of the existence of their tanks. Owner means--

(a) in the case of an underground storage tank in use on November 8, 1984, or brought into use after that date, any person who owns an underground storage tank used for storage, use, or dispensing of regulated substances, and

(b) in the case of any underground storage tank in use before November 8, 1984, but no longer in use on that date, any person who owned such tank immediately before discontinuation of its use.

What Tanks Are Included? Underground storage tank is defined as any one or combination of tanks that (1) is used to contain an accumulation of "regulated substances," and (2) whose volume (including connected underground piping) is 10% or more beneath the ground. Some examples are underground tanks storing: 1. gasoline, used oil or diesel fuel, and 2. industrial solvents, pesticides, herbicides or fumigants.

What Tanks Are Excluded? Tanks removed from the ground are not subject to notification. Other tanks excluded from notification are:

- farm or residential tanks of 1100 gallons or less capacity used for storing motor fuel for noncommercial purposes;
- tanks used for storing heating oil for consumptive use on the premises where stored;
- septic tanks;
- pipeline facilities (including gathering lines) regulated under the Natural Gas Pipeline Safety Act of 1968, or the Hazardous Liquid Pipeline Safety Act of 1979, or which is an intrastate pipeline facility regulated under State laws;
- surface impoundments, pits, ponds, or lagoons;
- storm water or waste water collection systems;
- flow-through process tanks;
- liquid traps or associated gathering lines directly related to oil or gas production and gathering operations;
- storage tanks situated in an underground area (such as a basement, cellar, mineworking, drift, shaft, or tunnel) if the storage tank is situated upon or above the surface floor;
- pipes connected to any tank which is exempt;
- tanks used for storing pesticides regulated under the SD Codified Law Chapter 38-21, except those regulated pursuant to subtitle I of the Federal Hazardous and Solid Waste amendments of 1984.

What Substances Are Covered? This includes any substance defined as hazardous in Section 101 (14) of the Comprehensive Environmental Response, Compensation and Liability Act of 1980 (CERCLA), with the exception of those substances regulated as hazardous waste under Subtitle C of RCRA. It also includes petroleum, e.g., crude oil or any fraction thereof which is liquid at standard conditions of temperature and pressure (60 degrees Fahrenheit and 14.7 pounds per square inch absolute).

Where To Notify? Send completed forms to:

**Ground Water Quality Program, Storage Tank Section
523 East Capitol, Pierre, SD 57501
Phone # (605) 773-3296**

When To Notify? 1. Owners of underground storage tanks in use or that have been taken out of operation after January 1, 1974, but still in the ground, must notify by May 8, 1986. 2. Owners who bring underground storage tanks into use after May 8, 1986, must notify within 30 days of bringing the tanks into use.

Penalties: Any owner who knowingly fails to notify or submits false information shall be subject to a civil penalty not to exceed \$10,000 for each tank for which notification is not given or for which false information is submitted.

I. OWNERSHIP OF TANK(S)			II. LOCATION OF TANK(S)		
Owner Name (Corporation, Individual, Public Agency, or Other Entity)			If known, give the geographic location of tanks by degrees, minutes, and seconds. Examples Lat. 42, 36, 12 N Long. 85, 24, 17 W		
Street Address			Latitude _____ Longitude _____		(if same as Section I, mark box here) <input type="checkbox"/>
			Facility Name or Company Site Identifier, as applicable		
Street Address			Street Address		
City	State	Zip Code			
County	City	State	Zip Code		
Phone Number (include Area Code)	County	Phone Number (include Area Code)			

Notification for Underground Storage Tanks

III. TYPE OF OWNER

- | | |
|---|-------------------------------------|
| <input type="checkbox"/> Federal Government | <input type="checkbox"/> Commercial |
| <input type="checkbox"/> State Government | <input type="checkbox"/> Private |
| <input type="checkbox"/> Local Government | |

IV. INDIAN LANDS

Tanks are located on land within an Indian Reservation or on other trust lands.
 Tanks are owned by native American nation, tribe, or individual

Tribe or Nation:

V. TYPE OF FACILITY

- | | | |
|--|---|---|
| <input type="checkbox"/> Gas Station | <input type="checkbox"/> Railroad | <input type="checkbox"/> Trucking/Transport |
| <input type="checkbox"/> Petroleum Distributor | <input type="checkbox"/> Federal - Non-Military | <input type="checkbox"/> Utilities |
| <input type="checkbox"/> Air Taxi (Airline) | <input type="checkbox"/> Federal - Military | <input type="checkbox"/> Residential |
| <input type="checkbox"/> Aircraft /Airport Owner | <input type="checkbox"/> Industrial | <input type="checkbox"/> Farm |
| <input type="checkbox"/> Auto Dealership/Repair Shop | <input type="checkbox"/> Contractor | <input type="checkbox"/> Other (Explain) |

VI. CONTACT PERSON IN CHARGE OF TANKS

Name:	Job Title:	Address:	Phone Number (Include Area Code):
-------	------------	----------	-----------------------------------

VII. FINANCIAL RESPONSIBILITY

I have met the financial responsibility requirements
 in accordance with 40 CFR Subpart H

Check All that Apply

- | | | |
|---|---|---|
| <input type="checkbox"/> Self Insurance | <input type="checkbox"/> Guarantee | <input type="checkbox"/> State Funds |
| <input type="checkbox"/> Commercial Insurance | <input type="checkbox"/> Surety Bond | <input type="checkbox"/> Trust Fund |
| <input type="checkbox"/> Risk Retention Group | <input type="checkbox"/> Letter of Credit | <input type="checkbox"/> Other Method Allowed - Specify |

VIII. CERTIFICATION

I certify under penalty of law that I have personally examined and am familiar with the information submitted in this and all attached documents, and that based on my inquiry of those individuals immediately responsible for obtaining the information, I believe that the submitted information is true, accurate, and complete.

Name and official title of owner or owner's
 authorized representative (Print)

Notification for Underground Storage Tanks

IX. DESCRIPTION OF UNDERGROUND STORAGE TANKS (Complete for each tank at this location.)

Tank Identification Number	Tank No.	Tank No.	Tank No.	Tank No.	Tank No.
1. Status of Tank (mark only one)					
Currently In Use	<input type="checkbox"/>	<input type="checkbox"/>	<input type="checkbox"/>	<input type="checkbox"/>	<input type="checkbox"/>
Temporarily Out of Use	<input type="checkbox"/>	<input type="checkbox"/>	<input type="checkbox"/>	<input type="checkbox"/>	<input type="checkbox"/>
Permanently Out of Use	<input type="checkbox"/>	<input type="checkbox"/>	<input type="checkbox"/>	<input type="checkbox"/>	<input type="checkbox"/>
2. Date of Installation (mo./year)					
3. Estimated Total Capacity (gallons)					
4. Material of Construction (mark all that apply)					
Asphalt Coated or Bare Steel	<input type="checkbox"/>	<input type="checkbox"/>	<input type="checkbox"/>	<input type="checkbox"/>	<input type="checkbox"/>
Manufactured Cathodically Protected Steel (sti-P ₃ Tank)	<input type="checkbox"/>	<input type="checkbox"/>	<input type="checkbox"/>	<input type="checkbox"/>	<input type="checkbox"/>
Field Installed Impressed Current	<input type="checkbox"/>	<input type="checkbox"/>	<input type="checkbox"/>	<input type="checkbox"/>	<input type="checkbox"/>
Epoxy Coated Steel	<input type="checkbox"/>	<input type="checkbox"/>	<input type="checkbox"/>	<input type="checkbox"/>	<input type="checkbox"/>
Composite (Steel with Fiberglass)	<input type="checkbox"/>	<input type="checkbox"/>	<input type="checkbox"/>	<input type="checkbox"/>	<input type="checkbox"/>
Fiberglass Reinforced Plastic	<input type="checkbox"/>	<input type="checkbox"/>	<input type="checkbox"/>	<input type="checkbox"/>	<input type="checkbox"/>
Lined Interior	<input type="checkbox"/>	<input type="checkbox"/>	<input type="checkbox"/>	<input type="checkbox"/>	<input type="checkbox"/>
Double Walled	<input type="checkbox"/>	<input type="checkbox"/>	<input type="checkbox"/>	<input type="checkbox"/>	<input type="checkbox"/>
Polyethylene Tank Jacket	<input type="checkbox"/>	<input type="checkbox"/>	<input type="checkbox"/>	<input type="checkbox"/>	<input type="checkbox"/>
Concrete	<input type="checkbox"/>	<input type="checkbox"/>	<input type="checkbox"/>	<input type="checkbox"/>	<input type="checkbox"/>
Excavation Liner	<input type="checkbox"/>	<input type="checkbox"/>	<input type="checkbox"/>	<input type="checkbox"/>	<input type="checkbox"/>
Unknown	<input type="checkbox"/>	<input type="checkbox"/>	<input type="checkbox"/>	<input type="checkbox"/>	<input type="checkbox"/>
Other, Please specify	_____	_____	_____	_____	_____
Has tank been repaired?	<input type="checkbox"/>	<input type="checkbox"/>	<input type="checkbox"/>	<input type="checkbox"/>	<input type="checkbox"/>
5. Piping (Material) (mark all that apply)					
Bare Steel	<input type="checkbox"/>	<input type="checkbox"/>	<input type="checkbox"/>	<input type="checkbox"/>	<input type="checkbox"/>
Galvanized Steel	<input type="checkbox"/>	<input type="checkbox"/>	<input type="checkbox"/>	<input type="checkbox"/>	<input type="checkbox"/>
Fiberglass Reinforced Plastic	<input type="checkbox"/>	<input type="checkbox"/>	<input type="checkbox"/>	<input type="checkbox"/>	<input type="checkbox"/>
Copper	<input type="checkbox"/>	<input type="checkbox"/>	<input type="checkbox"/>	<input type="checkbox"/>	<input type="checkbox"/>
Cathodically Protected	<input type="checkbox"/>	<input type="checkbox"/>	<input type="checkbox"/>	<input type="checkbox"/>	<input type="checkbox"/>
Double Walled	<input type="checkbox"/>	<input type="checkbox"/>	<input type="checkbox"/>	<input type="checkbox"/>	<input type="checkbox"/>
Secondary Containment	<input type="checkbox"/>	<input type="checkbox"/>	<input type="checkbox"/>	<input type="checkbox"/>	<input type="checkbox"/>
Unknown	<input type="checkbox"/>	<input type="checkbox"/>	<input type="checkbox"/>	<input type="checkbox"/>	<input type="checkbox"/>
Other, Please Specify	_____	_____	_____	_____	_____
6. Piping (Type) (mark all that apply)					
Suction: no valve at tank	<input type="checkbox"/>	<input type="checkbox"/>	<input type="checkbox"/>	<input type="checkbox"/>	<input type="checkbox"/>
Suction: valve at tank	<input type="checkbox"/>	<input type="checkbox"/>	<input type="checkbox"/>	<input type="checkbox"/>	<input type="checkbox"/>
Pressure	<input type="checkbox"/>	<input type="checkbox"/>	<input type="checkbox"/>	<input type="checkbox"/>	<input type="checkbox"/>
Gravity Feed	<input type="checkbox"/>	<input type="checkbox"/>	<input type="checkbox"/>	<input type="checkbox"/>	<input type="checkbox"/>
Has piping been repaired?	<input type="checkbox"/>	<input type="checkbox"/>	<input type="checkbox"/>	<input type="checkbox"/>	<input type="checkbox"/>

Notification for Underground Storage Tanks

Tank Identification Number	Tank No.	Tank No.	Tank No.	Tank No.	Tank No.
7. Substance Currently or Last Stored in Greatest Quantity by Volume					
Gasoline	<input type="checkbox"/>	<input type="checkbox"/>	<input type="checkbox"/>	<input type="checkbox"/>	<input type="checkbox"/>
Diesel	<input type="checkbox"/>	<input type="checkbox"/>	<input type="checkbox"/>	<input type="checkbox"/>	<input type="checkbox"/>
Gasohol	<input type="checkbox"/>	<input type="checkbox"/>	<input type="checkbox"/>	<input type="checkbox"/>	<input type="checkbox"/>
Kerosene	<input type="checkbox"/>	<input type="checkbox"/>	<input type="checkbox"/>	<input type="checkbox"/>	<input type="checkbox"/>
Heating Oil	<input type="checkbox"/>	<input type="checkbox"/>	<input type="checkbox"/>	<input type="checkbox"/>	<input type="checkbox"/>
Used Oil	<input type="checkbox"/>	<input type="checkbox"/>	<input type="checkbox"/>	<input type="checkbox"/>	<input type="checkbox"/>
Aviation Fuel	<input type="checkbox"/>	<input type="checkbox"/>	<input type="checkbox"/>	<input type="checkbox"/>	<input type="checkbox"/>
Jet Fuel	<input type="checkbox"/>	<input type="checkbox"/>	<input type="checkbox"/>	<input type="checkbox"/>	<input type="checkbox"/>
E85	<input type="checkbox"/>	<input type="checkbox"/>	<input type="checkbox"/>	<input type="checkbox"/>	<input type="checkbox"/>
Other	<input type="checkbox"/>	<input type="checkbox"/>	<input type="checkbox"/>	<input type="checkbox"/>	<input type="checkbox"/>
Please Specify	_____	_____	_____	_____	_____
Hazardous Substance	<input type="checkbox"/>	<input type="checkbox"/>	<input type="checkbox"/>	<input type="checkbox"/>	<input type="checkbox"/>
CERCLA name and/or CAS number	_____ _____	_____ _____	_____ _____	_____ _____	_____ _____
Mixture of Substances	<input type="checkbox"/>	<input type="checkbox"/>	<input type="checkbox"/>	<input type="checkbox"/>	<input type="checkbox"/>
Please Specify	_____	_____	_____	_____	_____

X. TANKS OUT OF USE, OR CHANGE IN SERVICE

1. Closing of Tank					
A. Estimated date last used (mo./day/year)					
B. Estimated date tank closed (mo./day/year)					
C. Tank was removed from ground	<input type="checkbox"/>	<input type="checkbox"/>	<input type="checkbox"/>	<input type="checkbox"/>	<input type="checkbox"/>
D. Tank was closed in ground	<input type="checkbox"/>	<input type="checkbox"/>	<input type="checkbox"/>	<input type="checkbox"/>	<input type="checkbox"/>
E. Tank filled with inert material	<input type="checkbox"/>	<input type="checkbox"/>	<input type="checkbox"/>	<input type="checkbox"/>	<input type="checkbox"/>
Describe	_____ _____ _____	_____ _____ _____	_____ _____ _____	_____ _____ _____	_____ _____ _____
F. Change in service	<input type="checkbox"/>	<input type="checkbox"/>	<input type="checkbox"/>	<input type="checkbox"/>	<input type="checkbox"/>
2. Site Assessment Completed (DENR Spill Number, if known)	<input type="checkbox"/>	<input type="checkbox"/>	<input type="checkbox"/>	<input type="checkbox"/>	<input type="checkbox"/>
3. Evidence of a leak detected	<input type="checkbox"/>	<input type="checkbox"/>	<input type="checkbox"/>	<input type="checkbox"/>	<input type="checkbox"/>

Notification for Underground Storage Tanks

XI. CERTIFICATION OF COMPLIANCE (COMPLETE FOR ALL NEW AND UPGRADED TANKS AT THIS LOCATION)

Tank Identification Number	Tank No.	Tank No.	Tank No.	Tank No.	Tank No.
1. Installation					
A. Installer certified by tank and piping manufacturers	<input type="checkbox"/>	<input type="checkbox"/>	<input type="checkbox"/>	<input type="checkbox"/>	<input type="checkbox"/>
B. Installer certified by other state	<input type="checkbox"/>	<input type="checkbox"/>	<input type="checkbox"/>	<input type="checkbox"/>	<input type="checkbox"/>
C. Installation inspected by a registered engineer	<input type="checkbox"/>	<input type="checkbox"/>	<input type="checkbox"/>	<input type="checkbox"/>	<input type="checkbox"/>
D. Installation inspected by DENR	<input type="checkbox"/>	<input type="checkbox"/>	<input type="checkbox"/>	<input type="checkbox"/>	<input type="checkbox"/>
E. Plan & Specification approved by DENR	<input type="checkbox"/>	<input type="checkbox"/>	<input type="checkbox"/>	<input type="checkbox"/>	<input type="checkbox"/>
F. Manufacturer's installation checklists have been completed	<input type="checkbox"/>	<input type="checkbox"/>	<input type="checkbox"/>	<input type="checkbox"/>	<input type="checkbox"/>
G. Another method allowed by DENR. Please specify.	_____	_____	_____	_____	_____
2. Release Detection (Mark all that apply)	TANK	PIPING	TANK	PIPING	TANK
A. Manual tank gauging	<input type="checkbox"/>		<input type="checkbox"/>		<input type="checkbox"/>
B. Tank tightness testing	<input type="checkbox"/>		<input type="checkbox"/>		<input type="checkbox"/>
C. Inventory Controls	<input type="checkbox"/>		<input type="checkbox"/>		<input type="checkbox"/>
D. Automatic tank gauging	<input type="checkbox"/>		<input type="checkbox"/>		<input type="checkbox"/>
E. Vapor monitoring	<input type="checkbox"/>	<input type="checkbox"/>	<input type="checkbox"/>	<input type="checkbox"/>	<input type="checkbox"/>
F. Groundwater monitoring	<input type="checkbox"/>	<input type="checkbox"/>	<input type="checkbox"/>	<input type="checkbox"/>	<input type="checkbox"/>
G. Interstitial monitoring/secondary containment	<input type="checkbox"/>	<input type="checkbox"/>	<input type="checkbox"/>	<input type="checkbox"/>	<input type="checkbox"/>
H. Automatic line leak detectors	<input type="checkbox"/>	<input type="checkbox"/>	<input type="checkbox"/>	<input type="checkbox"/>	<input type="checkbox"/>
I. Line tightness testing	<input type="checkbox"/>	<input type="checkbox"/>	<input type="checkbox"/>	<input type="checkbox"/>	<input type="checkbox"/>
J. Other method allowed by DENR.	<input type="checkbox"/>	<input type="checkbox"/>	<input type="checkbox"/>	<input type="checkbox"/>	<input type="checkbox"/>
Please specify	_____	_____	_____	_____	_____
3. Corrosion Protection (if applicable)					
List Tank Potentials	<input type="checkbox"/>	<input type="checkbox"/>	<input type="checkbox"/>	<input type="checkbox"/>	<input type="checkbox"/>
4. Spill and Overfill Protection					
A. Overfill device installed	<input type="checkbox"/>	<input type="checkbox"/>	<input type="checkbox"/>	<input type="checkbox"/>	<input type="checkbox"/>
Please specify	_____	_____	_____	_____	_____
B. Spill device installed	<input type="checkbox"/>	<input type="checkbox"/>	<input type="checkbox"/>	<input type="checkbox"/>	<input type="checkbox"/>

OATH: I certify the information concerning installation that is provided in section XI is true to the best of my belief and knowledge.

Installer: _____ Date _____

Name

Date

Position

Company



Change of Ownership Notification Form

GENERAL INFORMATION

STATE USE ONLY

State and Federal laws require notification of any ownership changes of regulated underground and aboveground storage tank systems within 30 days of acquisition.

Who To Notify? Send completed forms to:
Ground Water Quality Program, Storage Tank Section
523 East Capitol Ave, Pierre, SD 57501
Phone # (605) 773-3296, Fax # (605) 773-6035
<http://denr.sd.gov/tanks>

FACILITY ID NUMBER:

DATE RECEIVED:

A. Date Entered into Computer
B. Data Entry Clerk Initials

Facility - Location (Do Not Use P.O. Box)

New Owner

Facility Name

Name

Street Address

Street Address

City

State

Zip Code

City

State

Zip Code

County

County

Phone Number (Include Area Code)

Phone Number (Include Area Code)

DENR Facility ID Number

Facility Type (Underground Storage Tank/Aboveground Storage Tank)

Previous Owner

New Owner Invoice Mailing Address (If Different)

Name _____

Name _____

Address _____

Address _____

City _____

City _____

State/Zip _____

State/Zip _____

Phone _____

Phone _____

Fax _____

Fax _____

Certification: I certify that the following is true and accurate: (please check all that apply)

- I am familiar with Administrative Rules of South Dakota Chapter 74:56:01, regarding UST requirements.
- I am familiar with Administrative Rules of South Dakota Chapter 74:56:03, regarding AST requirements.

Notice Submitted By: [] Owner [] Operator [] Other:

(Please print name)

(Title)

(Date)

(Phone)

(Fax)



Alternative Fuel Compatibility Notification Form

Instructions: This form is to be completed and submitted to the South Dakota Department of Environment and Natural Resources at least 30 days prior to changing the contents of an underground storage tank (UST) to alternative fuels greater than 10% ethanol or greater than 20% biodiesel. This form will be used to verify the compatibility of UST system with the substance stored. The tank, pipe, and dispenser information should be completed by someone knowledgeable of the tank system in question. Note: Tanks with interior lining will not be approved for alternative fuel storage.

A completed form can be submitted to the DENR by mail, online, or fax:
South Dakota Department of Environment and Natural Resources
Ground Water Quality Program
523 East Capitol Avenue, Pierre, SD 57501
Phone: (605) 773-3296; Fax: (605) 773-6035
<https://denr.sd.gov/>

Facility Information

Facility ID#: _____
Facility Name: _____
Address: _____
City: _____ Zip code: _____
County: _____

Owner Information

Name: _____
Company Name: _____
Address: _____
City: _____ Zip code: _____
Phone: _____ Fax: _____
Email: _____

Contractor Information

Contractor Name: _____
Address: _____
City: _____
State: _____ Zip code: _____
Phone: _____

Tank Information

Size (gal.): _____
Manufacturer: _____
Tank material: _____
Tank single /double wall: _____
Installation date (year): _____

Tank leak detection method

- Automatic Tank Gauge
 Interstitial Monitoring
 Inventory Control
 Manual Tank Gauging
 Statistical Inventory Control

Ethanol percentage: _____ % **Biodiesel percentage:** _____ %

Identify the Manufacturer, Model/Brand, and whether the piece of equipment is Underwriters Laboratories (UL) listed or Manufacturer approved for utilization with the alternative fuel indicated above.

Tank	Manufacturer	Model/Brand	UL/Manufacturer approved?		
			UL (Y/N)	UL number	Man. (Y/N)
Spill Bucket			<input type="checkbox"/> Yes <input type="checkbox"/> No		<input type="checkbox"/> Yes <input type="checkbox"/> No
Overfill Device			<input type="checkbox"/> Yes <input type="checkbox"/> No		<input type="checkbox"/> Yes <input type="checkbox"/> No
Drop Tube			<input type="checkbox"/> Yes <input type="checkbox"/> No		<input type="checkbox"/> Yes <input type="checkbox"/> No
Submersible Pump/ Suction Pump			<input type="checkbox"/> Yes <input type="checkbox"/> No		<input type="checkbox"/> Yes <input type="checkbox"/> No
ATG Probes			<input type="checkbox"/> Yes <input type="checkbox"/> No		<input type="checkbox"/> Yes <input type="checkbox"/> No
Liquid Sensors			<input type="checkbox"/> Yes <input type="checkbox"/> No		<input type="checkbox"/> Yes <input type="checkbox"/> No

Piping

Manufacturer: _____ Model/Brand: _____

Pipe Material single/double wall: _____ Installation date (year): _____

UL/Manufacturer approved?					
Pipe construction material	Manufacturer	Model/Brand	UL (Y/N)	UL number	Man. (Y/N)
Pipe Fittings/ Valve Material			<input type="checkbox"/> Yes <input type="checkbox"/> No		<input type="checkbox"/> Yes <input type="checkbox"/> No
Gaskets/Seals			<input type="checkbox"/> Yes <input type="checkbox"/> No		<input type="checkbox"/> Yes <input type="checkbox"/> No
Pipe Sealant/ Adhesive			<input type="checkbox"/> Yes <input type="checkbox"/> No		<input type="checkbox"/> Yes <input type="checkbox"/> No
Flex Connector			<input type="checkbox"/> Yes <input type="checkbox"/> No		<input type="checkbox"/> Yes <input type="checkbox"/> No
Line Leak Detector			<input type="checkbox"/> Yes <input type="checkbox"/> No		<input type="checkbox"/> Yes <input type="checkbox"/> No
Flow Restrictor			<input type="checkbox"/> Yes <input type="checkbox"/> No		<input type="checkbox"/> Yes <input type="checkbox"/> No

UL/Manufacturer approved?					
Dispenser Information	Manufacturer	Model/Brand	UL (Y/N)	UL number	Man. (Y/N)
Dispenser Piping			<input type="checkbox"/> Yes <input type="checkbox"/> No		<input type="checkbox"/> Yes <input type="checkbox"/> No
Dispenser Sump			<input type="checkbox"/> Yes <input type="checkbox"/> No		<input type="checkbox"/> Yes <input type="checkbox"/> No
Dispenser Sump Sensor			<input type="checkbox"/> Yes <input type="checkbox"/> No		<input type="checkbox"/> Yes <input type="checkbox"/> No
Gaskets/Seals			<input type="checkbox"/> Yes <input type="checkbox"/> No		<input type="checkbox"/> Yes <input type="checkbox"/> No
Blending Valve			<input type="checkbox"/> Yes <input type="checkbox"/> No		<input type="checkbox"/> Yes <input type="checkbox"/> No
Check Valve			<input type="checkbox"/> Yes <input type="checkbox"/> No		<input type="checkbox"/> Yes <input type="checkbox"/> No
Meter			<input type="checkbox"/> Yes <input type="checkbox"/> No		<input type="checkbox"/> Yes <input type="checkbox"/> No
Emergency/ Shear Valve			<input type="checkbox"/> Yes <input type="checkbox"/> No		<input type="checkbox"/> Yes <input type="checkbox"/> No
Fuel Filters			<input type="checkbox"/> Yes <input type="checkbox"/> No		<input type="checkbox"/> Yes <input type="checkbox"/> No
Break-Away			<input type="checkbox"/> Yes <input type="checkbox"/> No		<input type="checkbox"/> Yes <input type="checkbox"/> No
Nozzle(s)/Swivel(s)			<input type="checkbox"/> Yes <input type="checkbox"/> No		<input type="checkbox"/> Yes <input type="checkbox"/> No
Hose(s)			<input type="checkbox"/> Yes <input type="checkbox"/> No		<input type="checkbox"/> Yes <input type="checkbox"/> No

Comments (Maximum 750 characters approximately):

Certification

I hereby certify that I have personally examined the tank system components and/or reviewed installation documentation, verifying the type of equipment installed.

agree - By agreeing, you certify the above statements to be true and correct, to the best of your knowledge, and that this information can be used for the purpose of processing this form.

Name of owner or owner's authorized representative:

Name: _____

Title: _____

Date (mm/dd/yyyy): _____

Tank Contractor:

Name: _____

Title: _____

Date (mm/dd/yyyy): _____

LEAK DETECTION

Owners or operators of new and existing UST systems must implement a leak (release) detection method or combination of methods for each UST in the system. Owners or operators must implement leak detection at least every 30 days to ensure the UST system is not leaking. The implemented primary leak detection method must be able to detect a release from any portion of the UST system that routinely contains product.

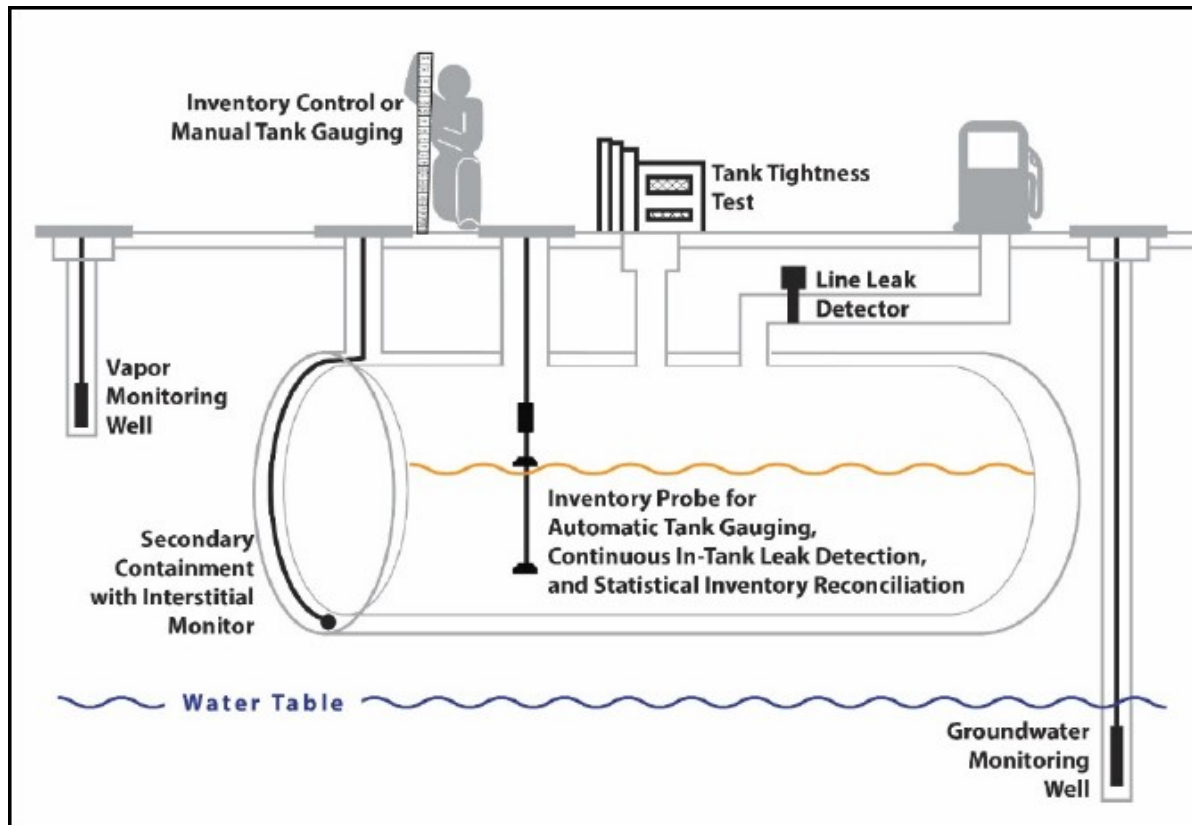

Leak detection methods available to the owner or operator include:

- Automatic tank gauging
- Secondary containment with interstitial monitoring
- Statistical inventory reconciliation
- Vapor monitoring
- Groundwater monitoring
- Manual tank gauging
- Manual tank gauging with tank tightness testing
- Inventory control and tank tightness testing

Leak Detection Certification

Leak detection equipment must be installed, calibrated, operated, and maintained according to the instructions of the manufacturer, and must meet method-specific performance requirements.

Certification of performance requirements from the manufacturer, vendor, or installer of release detection equipment must be retained, in addition to records of release detection system checks, calibration, maintenance, and repairs.

Leak detection equipment must be certified by an impartial third party. Third-party certification ensures leak detection equipment meets regulatory performance requirements. The National Work Group on Leak Detection Evaluations (NWGLDE), an independent workgroup of release detection experts, periodically evaluates all third-party certifications, and provides a free and reliable list of third-party certification evaluations for release detection equipment. Frequently updated, this information is available at <http://www.nwglde.org>

Automatic Tank Gauging

An automatic tank gauging (ATG) system consists of a probe permanently installed in an UST and wired to a monitor to provide information on product level and temperature. ATG systems automatically calculate changes in product volume that can indicate a leaking UST.

If an ATG system detects a leak or unusual conditions, a visual and audible alarm will trigger. Never ignore or silence ATG system alarms without investigation. It is the responsibility of the owner or operator to be knowledgeable and appropriately responsive to the indications of triggered alarms. If an alarm indicates a suspected or confirmed release, the DENR must be notified.



Operation and Maintenance

- The UST must contain enough product to ensure the validity and accuracy of ATG system test results.
- Most ATG systems require a minimum amount of product in the UST to properly perform a leak detection test. To determine the minimum amount of product required, refer to the ATG system operator manual or third-party certification.

Compliance Testing

- An ATG system, as a primary form of leak detection, must test for a 0.2 gallon per hour leak and produce a passing record for each UST in the system every 30 days.
- By October 13, 2021, all ATG systems must be tested annually for proper functionality by a qualified service contractor. At a minimum, the test must include alarm operability, system configuration verification, battery backup, and inspections of probes and sensors to ensure floats move freely, shaft is not damaged, cables are free of kinks and breaks, and controller communication is functioning properly.

Compliance Inspections and Recordkeeping

- Owners or operators must provide the most recent 12 months of passing ATG records for each UST in the system to the DENR for review.
- Owners or operators must provide the most recent annual ATG system functionality test to the DENR for review during compliance inspections.
- Owners or operators must retain the most recent 12 months of passing ATG records for each UST in the system.
- Owners or operators must retain the most recent ATG system functionality test results for 12 months, or until the next functionality test shows satisfactory operation of the ATG system.



DENR
SOUTH DAKOTA

Automatic Tank Gauge (ATG) Operational Testing Form

DEPARTMENT of ENVIRONMENT
and NATURAL RESOURCES
JOE FOSS BUILDING
523 EAST CAPITOL
PIERRE, SOUTH DAKOTA 57501-3182
denr.sd.gov

Facility Name:	Owner:
Address:	Mailing Address:
City, State, Zip Code:	City, State, Zip Code:
Facility ID#:	Phone#:
Testing Company:	Tester Name:

This procedure is to determine whether the Automatic Tank Gauge (ATG) is operating properly. See PELRP1200 Section 8.2 for the inspection procedure. This procedure is applicable to tank level monitor stems that touch the bottom of the tank when in place.

Tank Number				
Product Stored				
ATG Make and Model				
Tank Volume (gallons)				
Tank Diameter (inches)				
Have ATG probes been removed from the tank and inspected for damage and missing parts?	<input type="checkbox"/> Yes <input type="checkbox"/> No	<input type="checkbox"/> Yes <input type="checkbox"/> No	<input type="checkbox"/> Yes <input type="checkbox"/> No	<input type="checkbox"/> Yes <input type="checkbox"/> No
Do floats move freely without binding?	<input type="checkbox"/> Yes <input type="checkbox"/> No	<input type="checkbox"/> Yes <input type="checkbox"/> No	<input type="checkbox"/> Yes <input type="checkbox"/> No	<input type="checkbox"/> Yes <input type="checkbox"/> No
Is fuel float level consistent with the value programmed into the console?	<input type="checkbox"/> Yes <input type="checkbox"/> No	<input type="checkbox"/> Yes <input type="checkbox"/> No	<input type="checkbox"/> Yes <input type="checkbox"/> No	<input type="checkbox"/> Yes <input type="checkbox"/> No
Is water float level consistent with the value programmed into the console?	<input type="checkbox"/> Yes <input type="checkbox"/> No	<input type="checkbox"/> Yes <input type="checkbox"/> No	<input type="checkbox"/> Yes <input type="checkbox"/> No	<input type="checkbox"/> Yes <input type="checkbox"/> No
What level (inches) from the stem bottom does the 90% alarm trigger?				
Is the level (inches) at which the overflow alarm activates consistent with the value programmed in the console?	<input type="checkbox"/> Yes <input type="checkbox"/> No	<input type="checkbox"/> Yes <input type="checkbox"/> No	<input type="checkbox"/> Yes <input type="checkbox"/> No	<input type="checkbox"/> Yes <input type="checkbox"/> No
What level (inches) from the tank bottom does the water float first trigger an alarm?				
Does the level (inches) at which the water float alarm activates correspond with value programmed in the console?	<input type="checkbox"/> Yes <input type="checkbox"/> No	<input type="checkbox"/> Yes <input type="checkbox"/> No	<input type="checkbox"/> Yes <input type="checkbox"/> No	<input type="checkbox"/> Yes <input type="checkbox"/> No

Any "No" answer indicates a failed operational inspection

Test Results:	<input type="checkbox"/> Pass <input type="checkbox"/> Fail	<input type="checkbox"/> Pass <input type="checkbox"/> Fail	<input type="checkbox"/> Pass <input type="checkbox"/> Fail	<input type="checkbox"/> Pass <input type="checkbox"/> Fail
Testing Date:				

Secondary Containment with Interstitial Monitoring

Secondary containment with interstitial monitoring is a leak detection method that detects leaks in the space between the primary wall and a secondary barrier (interstitial space) of a UST. Interstitial monitoring may be used as a release detection method provided the interstitial space is monitored manually or automatically for evidence of a leak at least every 30 days and the secondary barrier is designed, constructed, and installed to ensure detection of any release from the UST system so corrective action can be initiated. The DENR must be notified if a leak is suspected or confirmed.

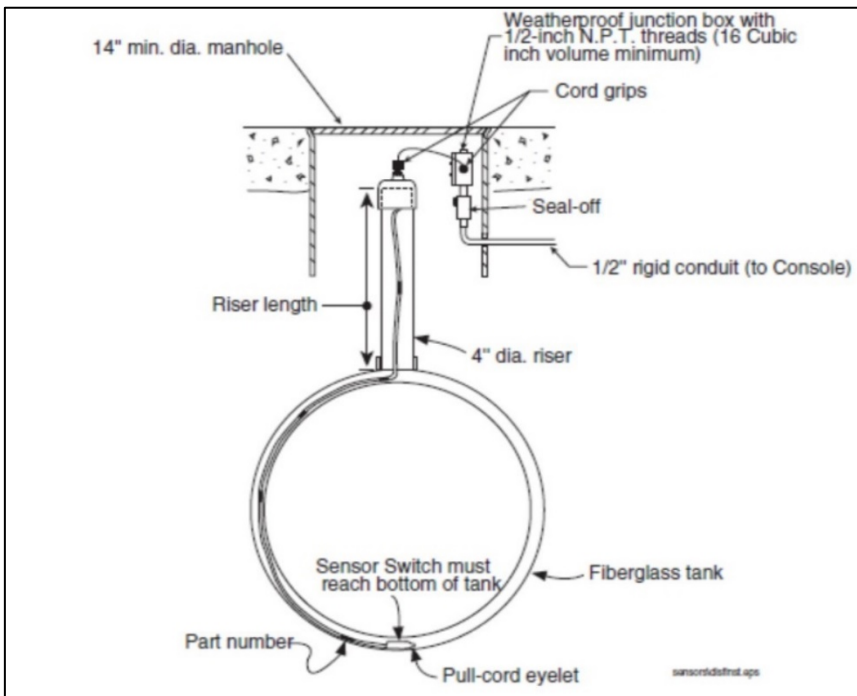

Operation and Maintenance

- Interstitial monitoring liquid sensors will alarm if water accumulates within the interstitial space. Any water detected in the interstice must be removed and properly disposed.

Compliance Testing

- The interstitial monitoring system must be tested or inspected for a leak every 30 days.
- Interstitial monitoring testing or inspection results must be documented every 30 days.
- The interstitial monitoring liquid sensor for each UST in the system must be annually tested for proper functionality by a qualified service contractor.

Compliance Inspections and Recordkeeping

- Owners or operators must provide the most recent 12 months of interstitial monitoring records for each UST in the system to the DENR during compliance inspections.
- Owners or operators must provide the most recent interstitial monitoring liquid sensor test results for each UST in the system to the DENR during compliance inspections.
- Owners or operators must retain the most recent 12 months of interstitial monitoring records for each UST in the system.
- Owners or operators must retain the most recent interstitial monitoring liquid sensor tests for each UST in the system for 12 months, or until the next functionality test shows satisfactory operation of the sensor.

Statistical Inventory Reconciliation

Statistical Inventory Reconciliation (SIR) is a leak detection method, which, typically, involves trained professionals who use sophisticated computer software to conduct a statistical analysis of inventory, delivery, and dispensing data for the UST system. Documentation of SIR results are

provided by the SIR vendor upon completion of statistical analysis. Computer programs also exist, which enable an owner or operator to perform their own SIR analysis. The DENR must be notified immediately if SIR results indicate a potential problem or confirm a leak.

Operation and Maintenance

- If an inventory measurement stick is used to gather data for an SIR vendor or in-house software, ensure the inventory stick is accurate to an eighth of an inch and able to measure product level at any height within the UST. The inventory measurement stick should be periodically inspected to ensure markings are legible and the stick bottom is not worn.

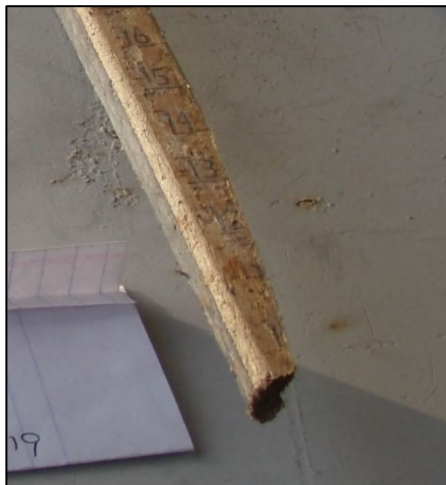

Compliance Requirements

- Inventory, delivery, and dispensing records must be provided to the SIR vendor at the frequency required for accurate statistical analyses.
- Documentation of SIR results must be received from the SIR vendor and reviewed every 30 days.

Compliance Inspections and Recordkeeping

- Owners or operators must provide the most recent 12 months of SIR results for the UST system to the DENR for review during compliance inspections.
- Owners and operators must retain the most recent 12 months of SIR results for the UST system.

Vapor Monitoring

Vapor monitoring is a leak detection method that monitors for either product vapors (passive monitoring) or tracer compound vapors (active monitoring) in the soil surrounding an UST. This method requires a porous backfill to allow vapors to migrate, so detection can be made within 30 days. Vapor monitoring should not be used with products such as diesel fuel, fuel oil, or used oil. The DENR must be notified if vapor monitoring equipment indicates a leak.



Operation and Maintenance

- Ensure vapor monitoring wells are clearly marked and secured.

Compliance Requirements

- Vapor monitoring equipment must be inspected for leaks every 30 days.
- Vapor monitoring equipment inspections must be recorded in a log.

Compliance Inspections and Recordkeeping

- Owners or operators must provide the most recent 12 months of vapor monitoring logs to the DENR for review during compliance inspections.
- Owners and operators must retain the most recent 12 months of vapor monitoring logs.

Groundwater Monitoring

Groundwater monitoring is a leak detection method that involves surveilling the groundwater table for free-phase product resulting from a leak in the UST system. Surveillance of the groundwater table is accomplished by inspecting groundwater monitoring wells placed near the UST system. To implement groundwater monitoring, a site assessment must be performed to determine the number and placement of groundwater monitoring wells, and the groundwater table must be less than 20 feet below the ground surface. The DENR must be notified if groundwater monitoring results indicate a leak.

Operation and Maintenance

- Ensure groundwater monitoring wells are clearly marked and secured.

Compliance Requirements

- Groundwater monitoring wells must be inspected every 30 days and recorded.

Compliance Inspections and Recordkeeping

- Owners or operators must provide the most recent 12 months of groundwater monitoring records to the DENR for review during compliance inspections.
- Owners and operators must retain the most recent 12 months of groundwater monitoring records.

Manual Tank Gauging

Manual Tank Gauging is a leak detection method only valid for UST of 1,000 gallons or less in capacity. Manual Tank Gauging involves taking a UST out of service for a testing period each week, during which the product level within a UST is measured twice at the beginning and twice at the end of the test period. The measurements are compared to weekly and monthly standards to determine if the UST is leaking. The DENR must be notified if an UST fails a weekly or monthly standard comparison.

Operation and Maintenance

- The inventory measurement stick must be accurate to the nearest eighth of an inch and able to measure product level at any height within the UST. The inventory measurement stick should be periodically inspected to ensure markings are legible and the stick bottom is not worn.

Compliance Requirements

- Once a week, each UST in the system must be taken out of service for the minimum test duration to obtain inventory measurements. Two inventory readings at the beginning of the test and two inventory readings after the undisturbed test duration must be obtained. The product level measurements are based on an average of the two beginning and ending inventory measurements, which must be recorded on a Manual Tank Gauging Record, as shown on page 20.
- Inventory readings should be reconciled weekly and monthly. Reconciled values must then be compared to the weekly and monthly standards shown on page 20.

Recordkeeping

- Owners or operators must provide 12 months of manual tank gauging records for each UST in the system to the DENR for review during compliance inspections.
- Owner or operators must retain the most recent 12 months of manual tank gauging records.

Manual Tank Gauging with Tank Tightness Testing

Manual Tank Gauging with Tank Tightness Testing is a temporary leak detection method, valid only for USTs of 2,000 gallons or less in capacity, which must be combined with monthly inventory control and periodic tank tightness testing. Manual Tank Gauging involves taking a UST out of service for the testing period (at least 36 hours) each week, during which the product level within a UST is measured twice at the beginning and twice at the end of the test period. The measurements are to be compared to weekly and monthly standards to determine if the UST is leaking. This combined method also includes tightness testing, a sophisticated test performed by trained professionals. The DENR must be notified if an UST fails a tightness test or a weekly or monthly standard comparison.

Operation and Maintenance

- The inventory measurement stick must be accurate to the nearest eighth of an inch and able to measure the product level at any height within the UST. The inventory measurement stick should be periodically inspected to ensure markings are intelligible and the stick bottom is not worn.

Compliance Requirements

- Once a week, each UST in the system must be taken out of service for the minimum test duration to obtain inventory measurements. Two inventory readings at the beginning of the test and two inventory readings after the undisturbed test duration must be obtained. The product level measurements are based on an average of the two beginning and ending inventory measurements. These measurements must be recorded on a Manual Tank Gauging Record, as shown on page 20.
- Inventory readings should be reconciled weekly and monthly. Reconciled values must then be compared to the weekly and monthly standards shown on page 20.
- Tank tightness testing must be performed by a qualified individual every five years until ten years after the UST was installed.
- This leak detection method can only be used temporarily for up to 10 years after installation of the UST, after which an alternate approved leak detection method must be implemented.

Recordkeeping

- Owners or operators must provide the most recent 12 months of manual tank gauging records for each UST in the system and the most recent UST tightness test(s) to the DENR for review during compliance inspections.
- Owners and operators should retain the most recent 12 months of manual tank gauging records and all UST tightness test records.

Manual Tank Gauging Record

Month/Year : _____/_____

Tank Identification & Type Of Fuel: _____

Date Of Water Check: _____ Level (Inches): _____ Facility Name: _____

YEAR: ____ START DATE (MONTH/DAY)	LENGTH OF TEST (HOURS)	START		END		CHANGE IN VOLUME (WEEKLY)	PASS WEEKLY TEST	CHANGE IN VOLUME (MONTHLY AVERAGE)	PASS MONTHLY TEST
		AVE INCH	GAL	AVE INC	GAL				
							Y N		
							Y N		Y N
							Y N		
							Y N		
							Y N		
							Y N		Y N
							Y N		
							Y N		
							Y N		
							Y N		Y N
							Y N		
							Y N		
							Y N		
							Y N		Y N
							Y N		
							Y N		
							Y N		

Table of Test Standards for Manual Tank Gauging

Tank Size	Minimum Duration Of Test	Weekly Standard (1 test)	Monthly Standard (4-test average)
up to 550 gallons	36 hours	10 gallons	5 gallons
551-1,000 gallons (when tank diameter is 64")	44 hours	9 gallons	4 gallons
551-1,000 gallons (when tank diameter is 48")	58 hours	12 gallons	6 gallons
1,001-2,000 gallons (also requires periodic tank tightness testing)	36 hours	26 gallons	13 gallons

Inventory Control and Tank Tightness Testing

Inventory Control with Tank Tightness Testing is a temporary leak detection method that combines monthly inventory control with periodic tank tightness testing. Inventory control involves taking measurements of tank contents and recording the amount of product pumped each operating day, measuring and recording tank deliveries, and reconciling data at least once a month. This combined method also includes tightness testing, a sophisticated test performed by trained professionals. The DENR must be notified if an UST fails a tightness test or a weekly or monthly standard comparison.

Operation and Maintenance

- The inventory measurement stick must be accurate to the nearest eighth of an inch and able to measure product level at any height within the UST. The inventory measurement stick should be periodically inspected to ensure markings are intelligible and the stick bottom is not worn.

Compliance Requirements

- Inventory readings must be obtained daily, records of product added or removed from the UST must be kept, and inventory data must be reconciled monthly.
- Inventory readings and monthly reconciliation data must be maintained on a monthly inventory record. An example of a monthly inventory record is shown on the following page.
- Tank tightness testing must be performed by a qualified individual every five years until ten years after the UST was installed.
- This leak detection method can only be used temporarily for up to 10 years after installation of the UST, after which an alternate approved leak detection method must be implemented.

Compliance Inspections and Recordkeeping

- The most recent 12 months of monthly inventory records for each UST in the system and the most recent UST tightness test(s) must be provided to the DENR for review during compliance inspections.
- Owners or operators must retain the most recent 12 months of Monthly Inventory Records and all UST tightness test records.

Monthly Inventory Record

Month/Year : _____ / _____

Tank Identification & Type Of Fuel: _____

Date Of Water Check: _____ Level (Inches): _____ Facility Name: _____

Date	Start Stick Inventory (Gallons)	Gallons Delivered	Gallons Pumped	Book Inventory (Gallons)	End Stick Inventory		Daily Over (+) Or Short (/) [End / Book]	Initials
					(Inches)	(Gallons)		
1	(+)	(-)	(=)					
2	(+)	(-)	(=)					
3	(+)	(-)	(=)					
4	(+)	(-)	(=)					
5	(+)	(-)	(=)					
6	(+)	(-)	(=)					
7	(+)	(-)	(=)					
8	(+)	(-)	(=)					
9	(+)	(-)	(=)					
7	(+)	(-)	(=)					
8	(+)	(-)	(=)					
9	(+)	(-)	(=)					
10	(+)	(-)	(=)					
11	(+)	(-)	(=)					
12	(+)	(-)	(=)					
13	(+)	(-)	(=)					
14	(+)	(-)	(=)					
15	(+)	(-)	(=)					
16	(+)	(-)	(=)					
17	(+)	(-)	(=)					
18	(+)	(-)	(=)					
19	(+)	(-)	(=)					
20	(+)	(-)	(=)					
21	(+)	(-)	(=)					
22	(+)	(-)	(=)					
23	(+)	(-)	(=)					
24	(+)	(-)	(=)					
25	(+)	(-)	(=)					
26	(+)	(-)	(=)					
27	(+)	(-)	(=)					
28	(+)	(-)	(=)					
29	(+)	(-)	(=)					
30	(+)	(-)	(=)					
31	(+)	(-)	(=)					

Total Gallons Pumped >

Total Gallons Over Or Short >

Leak Check:

Drop the last two digits from the **Total Gallons**

Pumped number and enter here: _____

+ 130 =

Compare these numbers

_____ gallons

Is the total gallons over or short **larger** than leak check result? **Yes No** (circle one)

If your answer is Yes for 2 months in a row, **notify DENR** as soon as possible.

Keep This Piece Of Paper On File For At Least 1 Year

Leak Detection for Product Piping

UST systems distribute product to dispensers via underground piping. Similar to USTs, underground product piping that routinely contains product must meet specific leak detection requirements. There are two types of distribution methods, including:

- Pressurized delivery systems
- Suction delivery systems

Release detection requirements for suction piping

Suction delivery UST systems use suction pumps located underneath dispensing units to draw product from the UST through underground piping.

Owners or operators of UST systems with underground piping that dispenses product under suction do not need to implement product piping leak detection, provided the following conditions are met:

- The underground piping operates at a pressure that is less than atmospheric.
- The underground piping slopes so the contents of the pipe will drain back into the UST if the suction is lost.
- The underground piping is equipped with only one check valve on each product line.
- The check valve is installed directly below and as close as practical to the suction pump.

Suction UST systems which do not meet the above conditions must implement one of the following leak detection methods:

- A line tightness test for each product pipe in the UST system every three years; or
- Monthly interstitial monitoring; or
- Monthly vapor monitoring; or
- Monthly groundwater monitoring; or
- Monthly SIR

Vapor monitoring, groundwater monitoring, and SIR have the same regulatory requirements for piping as they do for USTs.

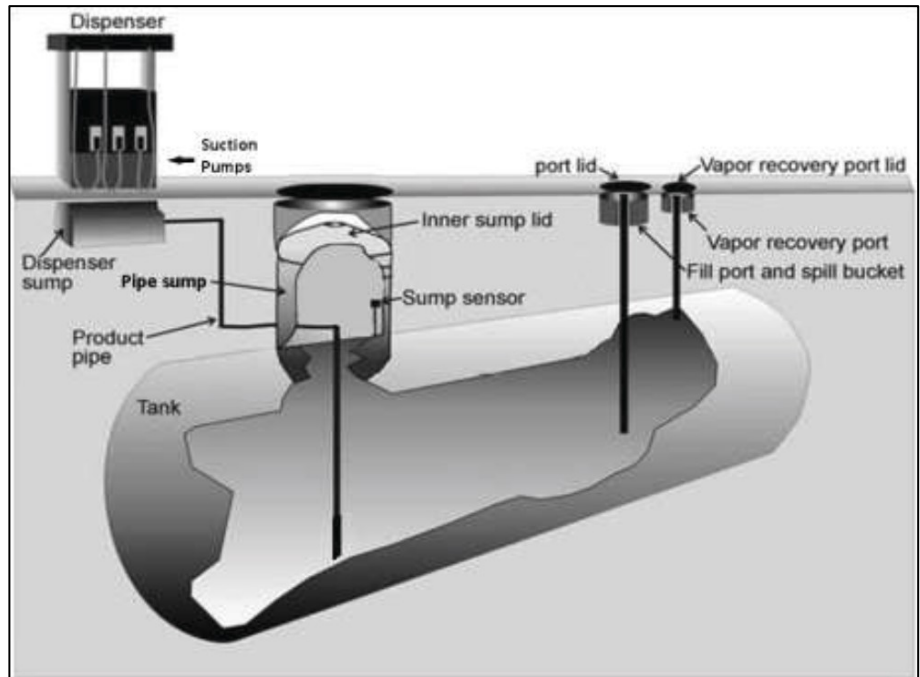

Leak Detection Requirements for Pressurized Piping.

Pressurized delivery UST systems use submersible turbine pumps (STPs) connected to underground piping to distribute product to the dispensers. Owners or operators of UST systems with underground piping that dispenses product under pressure must have leak detection for the piping connected to each UST. Underground piping leak detection for pressurized UST systems must meet the following requirements:

- The UST system must be equipped with automatic line leak detectors (LLDs) which detects the presence of a leak.
- The underground product piping must be annually tested for line tightness or monitored with equipment designed to detect a release from any portion of the underground piping that routinely contains product.

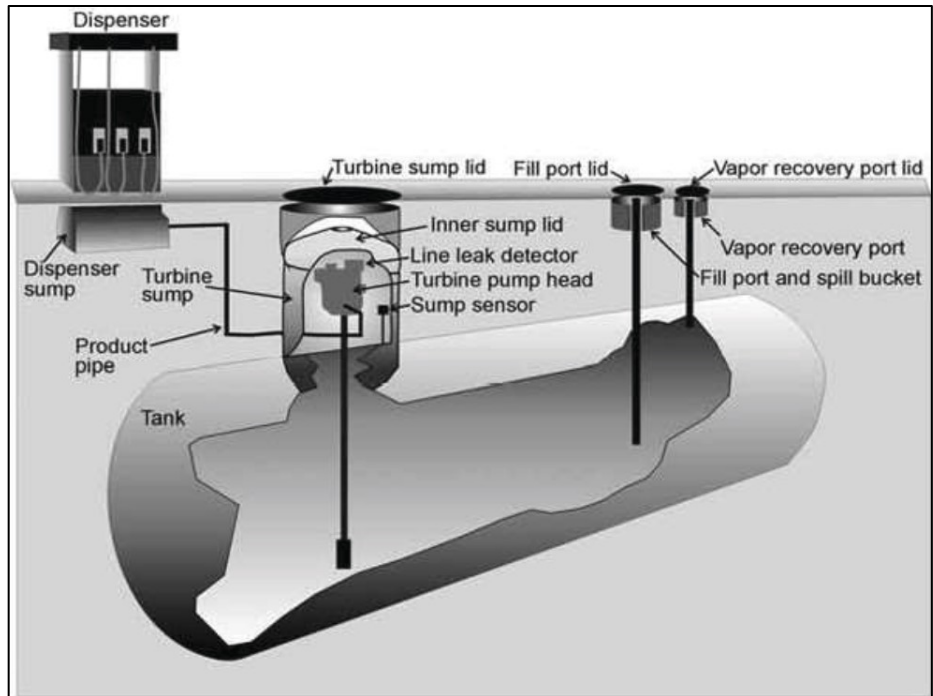

Automatic Line Leak Detection

A UST system with pressurized underground piping must be equipped with LLDs, which alert the current operator to the presence of a leak by restricting or shutting off the flow of product or triggering an audible or visible alarm. LLDs must be able to detect catastrophic leaks of 3 gallons per hour under 10 psi of line pressure within one hour.

LLDs are either mechanical or electronic and are located on the UST system STPs. Mechanical LLDs will restrict or shut off flow but do not trigger an alarm. Electronic LLDs restrict flow and trigger visual and audible alarms. If a tripped LLD confirms a leak, the DENR must be notified.



Compliance Testing

- LLDs must be tested annually for proper functionality by a qualified service contractor.

Compliance Inspections and Recordkeeping

- Owners or operators must provide the most recent LLD functionality testing results for each product line to the DENR for review during compliance inspections.
- Owners or operators must retain LLD functionality testing results for 12 months.

Line Tightness Testing

A line tightness test must be able to detect a leak of at least 0.1 gallon per hour when the line pressure is 1.5 times the normal operating pressure. Line tightness testing involves removing product piping from service and pressurizing the piping above normal operating pressure. A drop in pressure over time indicates a possible leak. A failed line tightness test must be reported to the DENR.

Compliance Testing

- Pressurized delivery UST systems must be tested annually for line tightness by a qualified service contractor.
- Suction delivery UST systems, if applicable, must be tested for line tightness once every three years by a qualified service contractor.



Compliance Inspections and Recordkeeping

- The most recent line tightness tests must be provided to the DENR during compliance inspections.
- The most recent line tightness tests should be retained for a minimum of 12 months, or until the next passing test is performed.

Interstitial Monitoring with Liquid Sump Sensors

Double walled secondarily contained product piping runs terminate within pump, dispenser, or transition containment sumps and uses liquid sump sensors, combined with automatic line leak detectors, to achieve the requirements of a primary leak detection method for product piping. This design should provide a favorable flow path in the event the inner pipe is compromised. Ideally, product should accumulate within containment sumps, causing the liquid sump sensors to send an electronic signal to a device (e.g., an ATG system) which triggers an alarm, notifying the current UST operator of a potential release. If a potential leak is confirmed, the DENR must be notified.

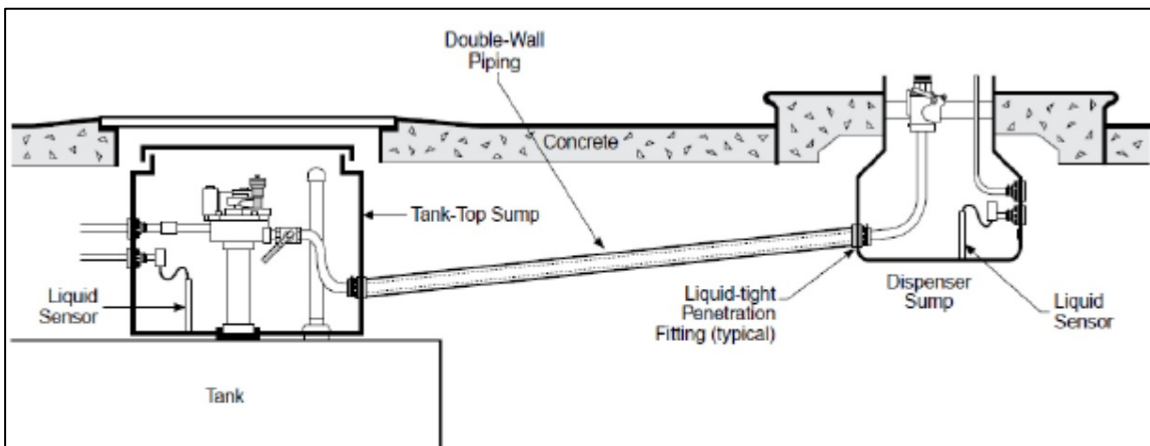

Operation and Maintenance

- Liquid sump sensors will alarm if water accumulates within containment sumps. If an alarm is triggered due to water, water must be removed and properly disposed.
- Liquid sump sensors must be positioned vertically and placed at the lowest point of the containment sump.

Compliance Testing

- Liquid sump sensors must be annually tested for proper functionality by a qualified service contractor.
- Containment sumps must be inspected monthly. Documentation of inspections is covered under Walk-Through Inspection on page 41.
- Containment sumps must be tested by a qualified service contractor by October 13, 2021, and at least once every three years after the initial test, to ensure the equipment is liquid tight by using vacuum, pressure, or liquid testing.
- For UST systems installed after October 13, 2018, containment sumps must be tested at installation and at least once every three years after the initial test.
- Vacuum, pressure, or liquid tightness testing is not required if containment sumps are double walled and the interstitial space inspected monthly and documented.
- An example of a containment sump equipment testing form is shown on page 27.

Compliance Inspections and Recordkeeping

- Owners or operators must provide the most recent liquid sump sensor functionality test to the DENR during compliance inspections.
- Owners or operators must retain the most recent liquid sump sensor functionality test for 12 months, or until the next passing test is completed.
- Owners or operators must provide the most recent containment sump equipment testing results.
- Owners or operators must retain the most recent containment sump equipment testing results for three years.
- Owners or operators must provide documentation of monthly sump and sensor inspections to the DENR during compliance inspections (Documentation for inspections is covered under Walk-Through Inspections on page 41).
- Owners or operators using monthly visual inspections of double walled equipment as a leak detection method must keep inspection records for as long as the method is used.



Containment Sump Equipment Testing Form

Facility Name:				Facility ID:		
Address:		Tester's Name:				
		Test Date:		Phone:		
Type of Containment Sump	<input type="checkbox"/> Dispenser <input type="checkbox"/> Transition <input type="checkbox"/> Tank Top	<input type="checkbox"/> Dispenser <input type="checkbox"/> Transition <input type="checkbox"/> Tank Top	<input type="checkbox"/> Dispenser <input type="checkbox"/> Transition <input type="checkbox"/> Tank Top	<input type="checkbox"/> Dispenser <input type="checkbox"/> Transition <input type="checkbox"/> Tank Top	<input type="checkbox"/> Dispenser <input type="checkbox"/> Transition <input type="checkbox"/> Tank Top	<input type="checkbox"/> Dispenser <input type="checkbox"/> Transition <input type="checkbox"/> Tank Top
Sump ID <small>(e.g. dispenser #, tank #, product, etc.)</small>						
Sump Material						
Construction	<input type="checkbox"/> Single Walled <input type="checkbox"/> Double Walled	<input type="checkbox"/> Single Walled <input type="checkbox"/> Double Walled	<input type="checkbox"/> Single walled <input type="checkbox"/> Double walled	<input type="checkbox"/> Single walled <input type="checkbox"/> Double walled	<input type="checkbox"/> Single walled <input type="checkbox"/> Double walled	<input type="checkbox"/> Single walled <input type="checkbox"/> Double walled
Free of Liquid and Debris	<input type="checkbox"/> Yes <input type="checkbox"/> No	<input type="checkbox"/> Yes <input type="checkbox"/> No	<input type="checkbox"/> Yes <input type="checkbox"/> No	<input type="checkbox"/> Yes <input type="checkbox"/> No	<input type="checkbox"/> Yes <input type="checkbox"/> No	<input type="checkbox"/> Yes <input type="checkbox"/> No
Visually Free of Cracks, Holes or Separations	<input type="checkbox"/> Yes (Pass) <input type="checkbox"/> No (Fail)	<input type="checkbox"/> Yes (Pass) <input type="checkbox"/> No (Fail)	<input type="checkbox"/> Yes (Pass) <input type="checkbox"/> No (Fail)	<input type="checkbox"/> Yes (Pass) <input type="checkbox"/> No (Fail)	<input type="checkbox"/> Yes (Pass) <input type="checkbox"/> No (Fail)	<input type="checkbox"/> Yes (Pass) <input type="checkbox"/> No (Fail)
Containment Sump Depth						
Height to Top of Highest Penetration						
Start Level						
Start Time						
Ending Level						
End Time						
Test Duration						
Liquid Level Change						
Test Results	<input type="checkbox"/> Pass <input type="checkbox"/> Fail	<input type="checkbox"/> Pass <input type="checkbox"/> Fail	<input type="checkbox"/> Pass <input type="checkbox"/> Fail	<input type="checkbox"/> Pass <input type="checkbox"/> Fail	<input type="checkbox"/> Pass <input type="checkbox"/> Fail	<input type="checkbox"/> Pass <input type="checkbox"/> Fail
Comments:						
Pass/Fail Criteria: Containment sumps must pass both the visual inspection and static testing duration, and must be performed in accordance with a code of practice developed by nationally recognized associations or similar industry standards.						
Was the test liquid disposed or reused? How was the test liquid disposed?						
Additional Comments:						

I certify under penalty of law that the above information is true, accurate and complete.

Tester's Signature _____

Spill and Overfill Prevention

All owners or operators must ensure that releases due to spills or overfills do not occur. The owner or operator shall ensure that the volume available in the tank is greater than the volume of product to be transferred to the tank before the transfer is made and a person is always physically present during the transfer. To prevent the potential for spills and overfills associated with product transfer to the UST system, owners or operators are required to use spill and overfill prevention equipment.

Spill Prevention

All new and existing UST systems must use spill prevention equipment, such as spill buckets or catchment basins, that will prevent release of product to the environment when a product transfer hose is detached from a UST fill pipe during a fuel delivery. Spill prevention equipment is designed to temporarily contain spilled product that might occur, and typically range from 5 to 25 gallons in capacity. To properly contain product, the spill prevention equipment must be liquid tight.

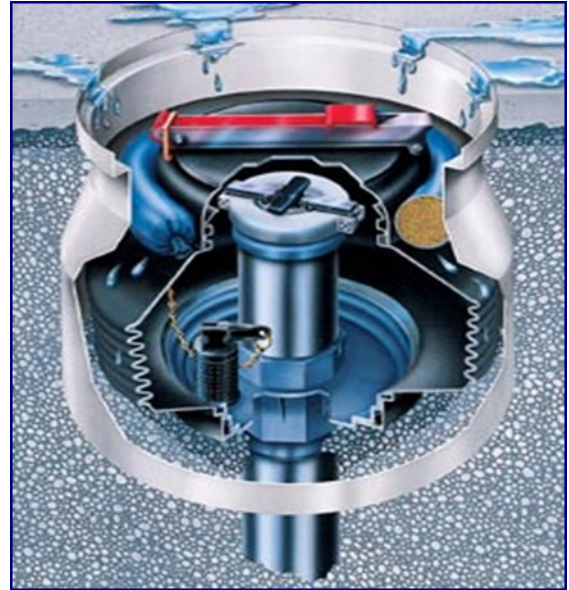

Operation and Maintenance

Spill prevention equipment is not designed to contain product for an extended amount of time. Spill prevention equipment must be kept free of liquid and debris. Any accumulated liquid or debris must be removed and properly disposed. Monthly owner/operator inspections also require visual assessment to ensure equipment is not damaged, is intact, and is liquid tight.

Compliance Testing

- Spill prevention equipment must be tested by a qualified service contractor by October 13, 2021, and at least once every three years after the initial test, to ensure the equipment is liquid tight by using vacuum, pressure, or liquid testing.
- For UST systems installed after October 13, 2018, spill prevention equipment must be tested at installation and at least once every three years after the initial test.
- Liquid tightness testing is not required if the spill prevention equipment is double walled and the interstitial space is inspected monthly and documented. An example of a spill prevention equipment testing form is shown on page 29.

Recordkeeping

- Owners and operators must provide the most recent spill prevention equipment testing results to the DENR during compliance inspections.
- Owners or operators must retain compliance testing records for at least three years.
- Records for monthly interstitial monitoring must be kept for as long as the method is used and provided to the DENR during inspections.



Spill Prevention Equipment Testing Form

Facility Name:				Facility ID:		
Address:		Tester's Name:				
		Test Date:		Phone:		
Tank Number						
Product Stored						
Capacity						
Manufacturer						
Construction	<input type="checkbox"/> Single Walled <input type="checkbox"/> Double Walled	<input type="checkbox"/> Single Walled <input type="checkbox"/> Double Walled	<input type="checkbox"/> Single Walled <input type="checkbox"/> Double Walled	<input type="checkbox"/> Single Walled <input type="checkbox"/> Double Walled	<input type="checkbox"/> Single Walled <input type="checkbox"/> Double Walled	<input type="checkbox"/> Single Walled <input type="checkbox"/> Double Walled
Free of Liquid and Debris	<input type="checkbox"/> Yes <input type="checkbox"/> No	<input type="checkbox"/> Yes <input type="checkbox"/> No	<input type="checkbox"/> Yes <input type="checkbox"/> No	<input type="checkbox"/> Yes <input type="checkbox"/> No	<input type="checkbox"/> Yes <input type="checkbox"/> No	<input type="checkbox"/> Yes <input type="checkbox"/> No
Visually Free of Cracks, Holes or Separations.	<input type="checkbox"/> Yes (Pass) <input type="checkbox"/> No (Fail)	<input type="checkbox"/> Yes (Pass) <input type="checkbox"/> No (Fail)	<input type="checkbox"/> Yes (Pass) <input type="checkbox"/> No (Fail)	<input type="checkbox"/> Yes (Pass) <input type="checkbox"/> No (Fail)	<input type="checkbox"/> Yes (Pass) <input type="checkbox"/> No (Fail)	<input type="checkbox"/> Yes (Pass) <input type="checkbox"/> No (Fail)
Tank Riser Cap Included in Test?	<input type="checkbox"/> Yes <input type="checkbox"/> No	<input type="checkbox"/> Yes <input type="checkbox"/> No	<input type="checkbox"/> Yes <input type="checkbox"/> No	<input type="checkbox"/> Yes <input type="checkbox"/> No	<input type="checkbox"/> Yes <input type="checkbox"/> No	<input type="checkbox"/> Yes <input type="checkbox"/> No
Is Drain Valve Included in Test?	<input type="checkbox"/> Yes <input type="checkbox"/> No <input type="checkbox"/> N/A	<input type="checkbox"/> Yes <input type="checkbox"/> No <input type="checkbox"/> N/A	<input type="checkbox"/> Yes <input type="checkbox"/> No <input type="checkbox"/> N/A	<input type="checkbox"/> Yes <input type="checkbox"/> No <input type="checkbox"/> N/A	<input type="checkbox"/> Yes <input type="checkbox"/> No <input type="checkbox"/> N/A	<input type="checkbox"/> Yes <input type="checkbox"/> No <input type="checkbox"/> N/A
Start Level						
Start Time						
Ending Level						
End Time						
Test Duration						
Change in Level						
Test Results	<input type="checkbox"/> Pass <input type="checkbox"/> Fail	<input type="checkbox"/> Pass <input type="checkbox"/> Fail	<input type="checkbox"/> Pass <input type="checkbox"/> Fail	<input type="checkbox"/> Pass <input type="checkbox"/> Fail	<input type="checkbox"/> Pass <input type="checkbox"/> Fail	<input type="checkbox"/> Pass <input type="checkbox"/> Fail
Comments:						
<p>Pass/Fail Criteria: Spill prevention equipment must pass both the visual inspection and static testing duration, and must be performed in accordance with a code of practice developed by nationally recognized associations or similar industry standards.</p>						
<p>Was the test liquid disposed or reused? How was the test liquid disposed?</p>						
<p>Additional Comments:</p>						

I certify under penalty of law that the above information is true, accurate and complete.

Tester's Signature _____

Overfill Prevention

All new and existing UST systems must use overfill prevention equipment to minimize the potential of releases into the environment through overfilling an UST during product delivery. There are three common types of overfill prevention equipment including: 1) automatic shutoff devices, 2) overfill alarms, and 3) ball float valves.

Automatic shutoff devices are designed to prevent overfills by automatically shutting off flow from the delivery truck once the UST reaches 95% capacity or before the fittings on top are exposed to product.

Overfill alarms use sensors to detect product level during delivery, activating visual and audible alerts for the delivery driver once the UST reaches 90% capacity or at least one minute before overfilling.

Ball float valves are designed to restrict flow from the delivery truck by preventing airflow once the UST reaches 90% capacity before overfilling (Note: As of October 13, 2018, ball float valves cannot be installed or replaced as an overfill prevention method).

In addition to the use of overfill prevention equipment, every effort must be made to assist delivery drivers from overfilling an UST. Overfills typically occur when the delivery driver makes a mistake or there is a communication error. Ensure signs are clearly marked and educate the delivery driver of the overfill equipment used for each UST.

Compliance Testing

- Overfill prevention equipment must be tested by a qualified service contractor for proper functionality by October 13, 2021, and at least once every three years after the initial test.
- At a minimum, the functionality test must ensure that overfill prevention equipment is set to activate at the correct level specified for the overfill prevention equipment and will activate when product reaches that level.
- For UST systems installed after October 13, 2018, overfill prevention equipment must be tested at installation and at least once every three years after the initial test.
- An example of an overfill prevention equipment testing form is shown on page 31.

Recordkeeping

- Owners and operators must provide the most recent overfill prevention equipment testing results to the DENR during compliance inspections.
- Owners and operators must retain overfill prevention equipment testing results for three years, or until the next passing test is completed.

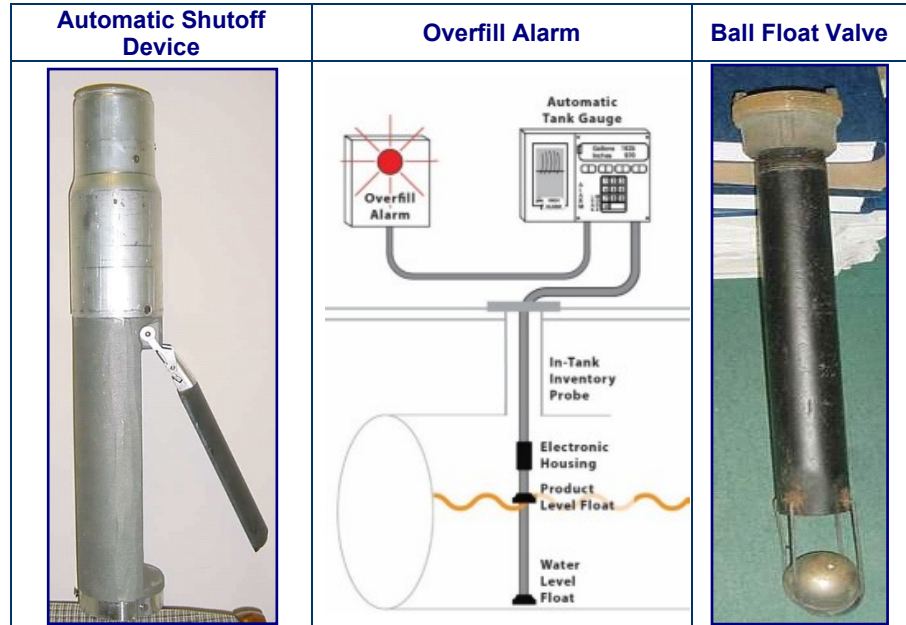

Overfill Prevention Equipment Testing Form

Facility Information

Facility Name: _____ Facility No. _____
 Facility Address: _____ Facility Owner: _____
 City: _____ State: _____ Zip Code: _____ Phone #: _____

Testing Contractor Information

Technician Conducting Test: _____
 Company Name: _____ Company Phone #: _____

Automatic Shutoff Device Inspection		Notes:			
Overfill Device Brand/Model					
Tank Number and Contents:	Tank #	Tank #	Tank #	Tank #	Tank #
Drop tube removed from tank?	<input type="checkbox"/> Yes <input type="checkbox"/> No	<input type="checkbox"/> Yes <input type="checkbox"/> No	<input type="checkbox"/> Yes <input type="checkbox"/> No	<input type="checkbox"/> Yes <input type="checkbox"/> No	<input type="checkbox"/> Yes <input type="checkbox"/> No
Drop Tube and float mechanisms free of debris?	<input type="checkbox"/> Yes <input type="checkbox"/> No	<input type="checkbox"/> Yes <input type="checkbox"/> No	<input type="checkbox"/> Yes <input type="checkbox"/> No	<input type="checkbox"/> Yes <input type="checkbox"/> No	<input type="checkbox"/> Yes <input type="checkbox"/> No
Float moves freely without binding and poppet moves into flow path?	<input type="checkbox"/> Yes <input type="checkbox"/> No	<input type="checkbox"/> Yes <input type="checkbox"/> No	<input type="checkbox"/> Yes <input type="checkbox"/> No	<input type="checkbox"/> Yes <input type="checkbox"/> No	<input type="checkbox"/> Yes <input type="checkbox"/> No
Bypass valve in the drop tube is open & free of blockage (if present)?	<input type="checkbox"/> Yes <input type="checkbox"/> No	<input type="checkbox"/> Yes <input type="checkbox"/> No	<input type="checkbox"/> Yes <input type="checkbox"/> No	<input type="checkbox"/> Yes <input type="checkbox"/> No	<input type="checkbox"/> Yes <input type="checkbox"/> No
Flapper valve adjusted to shut off flow at 95% ¹ or 90% ² capacity?	<input type="checkbox"/> Yes <input type="checkbox"/> No	<input type="checkbox"/> Yes <input type="checkbox"/> No	<input type="checkbox"/> Yes <input type="checkbox"/> No	<input type="checkbox"/> Yes <input type="checkbox"/> No	<input type="checkbox"/> Yes <input type="checkbox"/> No
Test Results:	<input type="checkbox"/> Pass <input type="checkbox"/> Fail	<input type="checkbox"/> Pass <input type="checkbox"/> Fail	<input type="checkbox"/> Pass <input type="checkbox"/> Fail	<input type="checkbox"/> Pass <input type="checkbox"/> Fail	<input type="checkbox"/> Pass <input type="checkbox"/> Fail
Ball Float Valve Inspection		Notes:			
Overfill Device Brand/Model					
Tank Number and Contents:	Tank #	Tank #	Tank #	Tank #	Tank #
Tank top fittings vapor tight/leak free?	<input type="checkbox"/> Yes <input type="checkbox"/> No	<input type="checkbox"/> Yes <input type="checkbox"/> No	<input type="checkbox"/> Yes <input type="checkbox"/> No	<input type="checkbox"/> Yes <input type="checkbox"/> No	<input type="checkbox"/> Yes <input type="checkbox"/> No
Ball float cage free of debris?	<input type="checkbox"/> Yes <input type="checkbox"/> No	<input type="checkbox"/> Yes <input type="checkbox"/> No	<input type="checkbox"/> Yes <input type="checkbox"/> No	<input type="checkbox"/> Yes <input type="checkbox"/> No	<input type="checkbox"/> Yes <input type="checkbox"/> No
Ball free of holes, cracks, & moves freely in cage?	<input type="checkbox"/> Yes <input type="checkbox"/> No	<input type="checkbox"/> Yes <input type="checkbox"/> No	<input type="checkbox"/> Yes <input type="checkbox"/> No	<input type="checkbox"/> Yes <input type="checkbox"/> No	<input type="checkbox"/> Yes <input type="checkbox"/> No
Vent hole in pipe open & near top of tank?	<input type="checkbox"/> Yes <input type="checkbox"/> No	<input type="checkbox"/> Yes <input type="checkbox"/> No	<input type="checkbox"/> Yes <input type="checkbox"/> No	<input type="checkbox"/> Yes <input type="checkbox"/> No	<input type="checkbox"/> Yes <input type="checkbox"/> No
Ball float pipe proper length to restrict flow at 90% capacity? ³	<input type="checkbox"/> Yes <input type="checkbox"/> No	<input type="checkbox"/> Yes <input type="checkbox"/> No	<input type="checkbox"/> Yes <input type="checkbox"/> No	<input type="checkbox"/> Yes <input type="checkbox"/> No	<input type="checkbox"/> Yes <input type="checkbox"/> No
Test Results:	<input type="checkbox"/> Pass <input type="checkbox"/> Fail	<input type="checkbox"/> Pass <input type="checkbox"/> Fail	<input type="checkbox"/> Pass <input type="checkbox"/> Fail	<input type="checkbox"/> Pass <input type="checkbox"/> Fail	<input type="checkbox"/> Pass <input type="checkbox"/> Fail
Overfill Alarm Inspection		This procedure determines whether the high level alarm is operational and will trigger when the tank is no more than 90% full.			
Tank Number and Contents:	Tank #	Tank #	Tank #	Tank #	Tank #
Fuel float level agrees with the gauge stick reading?	<input type="checkbox"/> Yes <input type="checkbox"/> No	<input type="checkbox"/> Yes <input type="checkbox"/> No	<input type="checkbox"/> Yes <input type="checkbox"/> No	<input type="checkbox"/> Yes <input type="checkbox"/> No	<input type="checkbox"/> Yes <input type="checkbox"/> No
The overfill alarm(s) activates when the tank is NO MORE than 90% full?	<input type="checkbox"/> Yes <input type="checkbox"/> No	<input type="checkbox"/> Yes <input type="checkbox"/> No	<input type="checkbox"/> Yes <input type="checkbox"/> No	<input type="checkbox"/> Yes <input type="checkbox"/> No	<input type="checkbox"/> Yes <input type="checkbox"/> No
Test Results:	<input type="checkbox"/> Pass <input type="checkbox"/> Fail	<input type="checkbox"/> Pass <input type="checkbox"/> Fail	<input type="checkbox"/> Pass <input type="checkbox"/> Fail	<input type="checkbox"/> Pass <input type="checkbox"/> Fail	<input type="checkbox"/> Pass <input type="checkbox"/> Fail

NOTE: A "No" to any item indicates a test failure. If a ball float is found to fail the inspection, another method of overfill prevention must be used.

- ¹ Use manufacturer's suggested procedure for determining if automatic shutoff device will shut off flow at 95% capacity.
- ² Use manufacturer's suggested procedure for determining if automatic shutoff device will shut off flow at 90% capacity for overfill prevention retrofits.
- ³ Use manufacturer's suggested procedure for determining if flow restriction device will shut off flow at 90% capacity.

Comments: _____

Technicians Signature: _____ **Date:** _____

Cathodic Protection

Cathodic protection for steel UST systems is an important preventive measure for the release of product into the environment through the destructive effects of corrosion. Corrosion results when bare metal and soil moisture conditions combine to produce an underground electric current that destroys hard metal. Over time, unprotected USTs can corrode and leak. To prevent leaks, all metallic components of an UST system that are underground and routinely contain product must be protected from corrosion. UST systems made entirely of noncorrodible material, such as fiberglass, do not need cathodic protection.



Galvanic (Sacrificial) Cathodic Protection

Galvanic cathodic protection uses sacrificial anodes, which are buried and attached to a UST and its associated components, for corrosion protection. Anodes are pieces of metal that are more electrically active than steel, and, as a result, the anodes suffer the destructive effects of corrosion rather than the steel to which the anodes are attached.

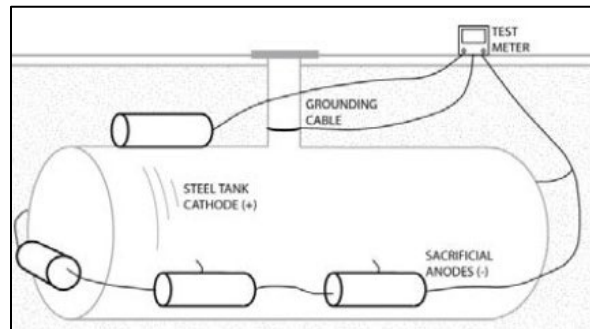

Compliance Testing

- A qualified corrosion tester must inspect the UST system cathodic protection within six months of installation and at least once every three years for the life of the system.
- Any cathodic protection repairs or upgrades also require verification testing within six months.
- If any test indicates the UST system is not adequately protected, the DENR must be notified and a corrosion specialist must be contacted to assess the system to make recommendations for corrective action. Except for minor repairs, modifications to a corrosion-protection system must be approved by DENR prior to implementation.

Compliance Inspections and Recordkeeping

- Owners and operators must provide the most recent galvanic cathodic protection test to the DENR during compliance inspections.
- Owners or operators must retain the last two most recent compliance inspection test results.

Impressed Current Cathodic Protection

Impressed current cathodic protection uses a rectifier to provide direct current through anodes to the UST and/or piping to achieve corrosion protection. The steel is protected because the current going to the steel overcomes the corrosion-causing current flowing away from it. The cathodic protection rectifier must always be on and operating to protect a UST system from corrosion.

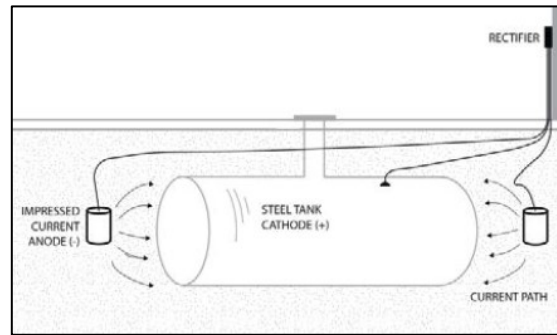

Compliance Testing

- A qualified corrosion tester must inspect the UST system impressed current cathodic protection within six months of installation and at least once every three years for the life of the system.
- If any test indicates the UST system is not adequately protected, the DENR must be notified and a corrosion specialist must be contacted to assess the system to make recommendations for corrective action.
- The owner or operator must inspect the impressed current cathodic protection rectifier at least every 60 days to ensure proper operation, and record voltage and amperage readouts in a rectifier log.
- Rectifier readings should be compared to previous records to ensure the impressed current cathodic protection is operating within designed parameters.
- If rectifier readings are outside of designed parameters, the DENR must be notified and a corrosion specialist must be contacted to assess the system to make recommendations for corrective action. Except for minor repairs, modifications to a corrosion-protection system must be approved by DENR prior to implementation.
- The rectifier should never be turned off. If the rectifier is turned off, the UST system is no longer protected from corrosion.

Compliance Inspections and Recordkeeping

- Owners or operators must provide the most recent impressed current cathodic protection test to the DENR for review during compliance inspections.
- Owners or operators must provide the three most recent impressed current cathodic protection logs to the DENR during compliance inspections.
- Owners or operators must retain the last two most recent impressed current cathodic protection test results.
- Owners or operators must retain the three most recent impressed current cathodic protection logs.

Internal Lining

Internal lining of steel USTs is a limited cathodic protection method available only to UST systems installed before December 22, 1998. This method involves internally lining a UST with a thick layer of noncorrodible material and is often combined with impressed current cathodic protection. There are two options for internally lined USTs to meet cathodic protection requirements, periodic internal inspections or impressed current cathodic protection tests.

Compliance Testing

- Internal Lining Only
 - Within 10 years after lining and at least every five years thereafter, the lined UST must be internally inspected by a trained professional to ensure structural integrity and performance according to the original design specifications.
- Internal Lining with Impressed Current Cathodic Protection
 - A qualified corrosion tester must inspect the UST system impressed current cathodic protection within six months of installation and at least every three years after for the life system.
 - If any test indicates the UST system is not adequately protected, the DENR must be notified and a corrosion specialist must be contacted to assess the system to make recommendations for corrective action. Except for minor repairs, modifications to a corrosion-protection system must be approved by DENR prior to implementation.
 - The owner or operator must inspect the impressed current cathodic protection rectifier at least every 60 days to ensure proper operation, and record voltage and amperage readouts in a rectifier log. Rectifier readings should be compared to previous records to ensure the impressed current cathodic protection is operating within designed parameters.
 - If rectifier readings are outside of designed parameters, the DENR must be notified and a corrosion specialist must be contacted to assess the system to make recommendations for corrective action.
 - The rectifier should never be turned off. If the rectifier is turned off, the UST system is no longer protected from corrosion.

Compliance Inspections and Recordkeeping

- Internal Lining Only
 - Owners and operators must provide the most recent internal lining inspection report to the DENR during compliance inspections.
 - Internal lining inspection reports should be maintained for the life of the UST.
- Internal Lining with Impressed Current Cathodic Protection
 - Owners and operators must provide the most recent impressed current cathodic protection test and impressed current cathodic protection rectifier log to the DENR during compliance inspections.
 - The results of the last two tests and at least the three most recent rectifier readings must be retained.



Cathodic Protection Testing Form

UST Owner		UST Facility	
NAME:		NAME:	ID#:
ADDRESS:		ADDRESS:	
CITY:	STATE:	CITY:	STATE:

Cathodic Protection Tester

TESTER'S NAME:		CP TESTER'S CERTIFICATION #:	
COMPANY NAME:		EXPIRATION DATE:	
ADDRESS:		PHONE NUMBER:	
CITY:	STATE:	CERTIFICATION TYPE (NACE AND/OR STI):	
Cathodic protection system is: <input type="checkbox"/> Galvanic <input type="checkbox"/> Impressed Current Date Last Tested:			

Weather Conditions at Time of Testing/Inspection:

Temperature: Soil/Backfill Conditions (check): moist dry sand gravel soil Describe soil:

Cathodic Protection System Certification

Identify which of the following testing situations is being recorded:

- Test required within 6 months of installation of CP system (installation date was _____)
- Test required at least every 3 years after installation/test noted above
- Test required within 6 months of any repair activity

The cathodic protection system is effective, testing was performed in accordance with nationally recognized industry standards, and is providing cathodic protection to all tanks and product lines:

Yes No

Signature of Tester _____

Date _____

UST SYSTEM INFORMATION

TANK #	YR TANK INSTALLED	CAPACITY	TANK CONTENTS	LINED	TANK MATERIAL	PIPING MATERIAL	FLEX CONNECTOR

Facility Name _____ Test Date _____ Facility # _____

IMPRESSED CURRENT CP TEST RESULTS REPORT PAGE							
RECTIFIER DATA							
RECTIFIER MANUFACTURER:				RATED DC OUTPUT:		VOLTS	AMPS
RECTIFIER MODEL:				RECTIFIER SERIAL NUMBER:			
RECTIFIER OUTPUT AS INITIALLY DESIGNED OR LAST RECOMMENDED (if available):						VOLTS	AMPS
	DATE	TAP SETTINGS		DC OUTPUT		HOURLY METER	COMMENTS
		Coarse	Fine	Volts	AMPS		
"As Found"							
"As Left"							
STRUCTURE TO SOIL POTENTIAL MEASUREMENTS							
ID	STRUCTURE	CONTACT POINT	REFERENCE CELL LOCATION	ON	INSTANT OFF	100MV	
						NATIVE	CHANGE
CP TEST STATION REQUIREMENTS							
Have previous CP system test records been reviewed? <input type="checkbox"/> Yes <input type="checkbox"/> No				Has this CP test been performed consistent with previous CP system tests? <input type="checkbox"/> Yes <input type="checkbox"/> No			
If test procedures have changed since last test please explain: _____ _____							
Have potential and continuity measurements been made at all tanks and piping including any buried flex-connectors? <input type="checkbox"/> Yes <input type="checkbox"/> No							
COMPLETE IF ANY REPAIRS OR MODIFICATIONS TO THE CP SYSTEM ARE MADE OR ARE NECESSARY							
Describe any repairs or modifications to the impressed current cathodic protection system that are made or are necessary. Repairs must be designed by a licensed CP expert.							
<input type="checkbox"/> Additional anodes for an impressed current system (attach corrosion experts design)							
<input type="checkbox"/> Repair and/or replacement of rectifier (explain below)							
<input type="checkbox"/> Repairs and/or replacement of cables (explain below)							
<input type="checkbox"/> Impressed current protected tanks/piping not electrically continuous (explain below)							
Remarks/Other: _____ _____ _____ _____							

Facility Name _____ Test Date _____ Facility # _____

GALVANIC (SACRIFICIAL) CP TEST RESULTS REPORT PAGE

STRUCTURE TO SOIL POTENTIAL AND MEASUREMENTS

ID	STRUCTURE	CONTACT POINT	REFERENCE CELL LOCATION	mV	COMMENTS

CP TEST STATION REQUIREMENTS

Have previous CP system test records been reviewed? Yes No

Has this CP test been performed consistent with previous CP system tests? Yes No

If test procedures have changed since last test please explain:

Have potential and continuity measurements been made at all tanks and piping, including any buried flex-connectors? Yes No

COMPLETE IF ANY REPAIRS OR MODIFICATIONS TO THE CP SYSTEM ARE MADE OR ARE NECESSARY

Describe any repairs or modifications to the cathodic protection system that are made or are necessary. Repairs must be designed by a qualified expert or in accordance with STI F- 1000

SITE DIAGRAM

Facility Name _____ Test Date _____ Facility # _____

Diagram showing the important parts of the facility (tanks, distribution lines, man way locations, submersible turbine pumps, vents, rectifier, dispensers, buildings, etc.). Indicate reference cell locations where structure-to-soil potential or continuity measurements have been made and label (R-1, R-2, R-3); location of all anodes and wires; location of CP test stations.

Tank Operator Training

Effective August 8, 2012, each owner and operator of any regulated UST system must complete a DENR approved training program on the proper operation of UST systems. All owners and operators must ensure they have designated Class A, Class B and Class C operators who have completed a DENR approved training program.

Class A Operators

Class A operators must have knowledge and skills to make informed decisions regarding compliance and determine whether appropriate individuals are fulfilling the operation, maintenance, and recordkeeping requirements.

Class B Operators

Class B operators must have knowledge and skills to implement applicable UST regulatory requirements in the field on components of typical UST systems or as applicable, site-specific equipment used at a UST facility.

Class C Operators

Class C operators must have knowledge and skills to take appropriate action (including notifying appropriate authorities) in response to emergencies or alarms caused by spills or releases from a UST system. Class C Operators must be trained by a Class A/B operator. Class C operator training can be performed and certified with the Class C Operator Training Certificate on the following page (page 40).





It is the responsibility of the Class A/B Operator to train Class C individuals. Class C Operators must be trained to address emergencies presented by a spill or leak from an underground storage tank system prior to taking daily responsibility. Class C Operators must be able to shut-off fuel pumps in case of emergency, respond to warnings and alarms, and properly report to the DENR and required local agencies.

FACILITY INFORMATION

Name: _____
Address: _____
City: _____
County: _____

What does a Class C Operator Need to Know in an Emergency?

- What is a spill or leak?
- Where is the shutoff switch or breaker for the dispensers/pumps?
- Who to call?
- Where is the absorbent material? Sandbags? Spill kit?
- What to do about an alarm?

What Does a Class C Operator Need To Do in an Emergency?

- If there is a fire, call 911 immediately.
- Stop the release of product from the UST system.
- Contain the release so it doesn't go down a storm drain, in the grass or off the property
- Call the main office or supervisor.
- Call DENR: (605) 773-3296. After Hours: (605) 773-3231

CERTIFICATION:

Class C Operator

By my signature below, I certify that I have received training in the areas mentioned above.

Print Name: _____
Signature: _____
Date: _____

Class A/B Operator

By my signature below, I certify that I have trained the employee named in this form.

Print Name: _____
Signature: _____
Date: _____

Walk-Through Inspections

Beginning October 13, 2021, regulated UST system owners or operators must begin monthly and annual walk-through inspections. Walk-through inspections must be conducted by or under the direction of a certified Class A/B Operator. Walk-through inspection results must be documented.



A walk-through inspection checklist is provided on the following page (page.42). A summary of monthly and annual walk-through inspections is detailed below.

Monthly Walk-Through Inspections

- Spill prevention equipment
 - Visually inspect spill prevention equipment for damage.
 - Remove liquid or debris.
 - Visually inspect fill pipes and remove any obstructions.
 - Ensure the fill cap fits securely on the fill pipe.
 - Visually inspect spill prevention equipment with interstitial monitoring and ensure there is not a leak in the interstitial area.
 - For UST systems receiving deliveries less frequently than every 30 days, the spill prevention equipment inspection may instead be conducted before each delivery.
- Leak detection equipment
 - Ensure release detection equipment is operating properly.
 - Ensure release detection equipment is not indicating an alarm or any other unusual operating condition.
 - Ensure release detection records are reviewed and current.
 - Owners and operators monitoring release detection systems remotely may review release detection equipment and records, provided release detection systems are in communication with remote monitoring equipment.

Annual Walk-Through Inspections

- Secondary containment sumps
 - Visually check for damage, leaks to the containment area, and releases to the environment.
 - Remove liquid from containment sumps.
 - Remove debris.
 - For double walled sumps with interstitial monitoring, check for leaks in the interstitial area.
- Hand-held release detection equipment
 - Check devices such as tank gauge sticks or groundwater bailers for operability and serviceability.



Walk-Through Inspection Checklist - Year: _____

Facility Name:							Facility ID:											
Address:				Class A/B Operator:														
Name(s) and initials of person(s) performing monthly walk-through inspections:																		
Please respond to <u>ALL</u> of the following questions with a Y (Yes), N (No), or NA (Not Applicable) answer.																		
Months of the Current Year							J	F	M	A	M	J	J	A	S	O	N	D
Monthly Inspection – Release Detection																		
1	Release detection equipment is operating normally without alarms or other unusual conditions.																	
2	Records of release detection (tanks and piping) are reviewed and current.																	
Monthly Inspection – Spill Prevention Equipment																		
3	Equipment is undamaged, intact, and free from defects.																	
4	Equipment is free from debris, water, or product.																	
5	Fill pipe for each tank is free from obstruction.																	
6	Fill cap for each tank is functional and fits securely on the fill pipe.																	
7	Double walled spill prevention equipment interstice is free of leaks.																	
Initials of person performing inspection																		
Annual Inspection – Containment Sumps							Date of Annual Inspection:											
8	Secondary containment sumps (STP, dispenser, and transition)		Containment sumps are undamaged and free from debris, water, and fuel. The penetration fittings for conduits and piping entering sumps are undamaged.															
9	Double walled sumps		Interstitial area is free from leaks.															
10	Hand-held release detection equipment		Hand-held release detection equipment (bailer, gauge stick, etc.) is serviceable and operable.															
11	Emergency shutoff switch		Emergency shutoff switch is visible and clearly marked, and at least 20' and no more than 80' from dispensers.															

I certify I am a Class A/B Operator, I am familiar with information on this form, and it is true and accurate.

Signature of Class A/B Operator (Sign this document <u>after</u> the last inspection of the current year)	Date:

Comments/Follow up:

Turn over for records of visual interstitial monitoring and impressed current rectifier readings.

If you perform Interstitial Monitoring on your tanks and/or piping and use a visual check rather than sump or interstitial sensors for your monthly leak detection, complete the table to document the monthly visual checks.													
	Months of the Current Year	J	F	M	A	M	J	J	A	S	O	N	D
1	Visual check of the interstitial space of the double-walled tank indicated no release or unusual operating conditions.												
2	Visual check of piping (STP, dispenser and transition) containment sumps indicates normal function and no indication of water or product.												

Impressed Current 60 Day Rectifier Log													
Months of the Current Year	J	F	M	A	M	J	J	A	S	O	N	D	
Date of impressed current cathodic protection rectifier inspection.													
Amperage reading from impressed current cathodic protection rectifier.													
Voltage reading from impressed current rectifier.													
Hours reading from impressed current cathodic protection rectifier.													

INSTRUCTIONS

1. The monthly UST system inspections must be conducted by or under the direction of a certified Class A/B Operator.
2. The UST Owner or Operator must maintain a copy of the walk-through inspection checklist for the most recent 12 months and shall be maintained on-site or off-site at a readily available location.

Leak Response and Reporting

Owners or operators of UST systems are responsible to report and properly respond to leaks. Indications of a potential leak, such as unusual operating conditions or leak detection alarms, must be reported to DENR as a suspected release and investigated immediately. A confirmed leak must be immediately reported to the DENR. Local laws or ordinances may also require spill reporting to local government entities.

Spills less than 25 gallons must be cleaned up within 24 hours. If the spill is not cleaned up within 24 hours, it must be reported.

Spills and/or overfills of product exceeding 25 gallons or any spill volume that is below ground or impacts surface water must be immediately reported to the DENR and applicable local agencies. Spills impacting surface water may also be reportable to the National Response Center (NRC) at 800-424-8802.

Owners or operators should complete the Leak Response and Reporting - Important Contact Information table below.

Leak Response and Reporting - Important Contact Information				
Agency	DENR	Emergency Management	Fire Department	Police or Sheriff
Contact Name				
Phone #	(605) 773-3296			911

Corrective actions for confirmed releases are outlined below:

Immediate Leak Response Actions

- Take immediate action to stop and contain the leak.
- Call for help if fire or emergency response is required.
- Identify and safely neutralize fire, explosion, or vapor hazards.
- Report suspected and confirmed leaks to the DENR.
- If necessary, remove product from the UST system to prevent further leaking into the environment.

Site Assessment

Based on the available information following immediate leak response actions, the DENR may require additional corrective assessment and/or remedial actions. A corrective action plan must be developed by an environmental consultant to meet the requirements established by the DENR.

Airport Hydrant and Field Constructed Systems

An airport hydrant system (AHS) is an UST system which fuels aircraft and operates under high pressure with large diameter piping that typically terminates into one or more hydrants or fill stands. The airport hydrant system begins where fuel enters one or more tanks from an external source such as a pipeline, barge, rail car, or other motor fuel carrier.

A field-constructed UST is constructed at the site of installation. This term includes USTs such as steel or fiberglass USTs primarily fabricated at the site of installation.

By October 13, 2018, owners and operators of an airport hydrant or field constructed UST system must meet the same requirements as other regulated UST systems. Airport hydrant and field constructed USTs installed after October 13, 2018 must meet these requirements at installation.

AHS and field-constructed USTs greater than 50,000 gallons must follow specific guidelines, which are outlined on EPA's website:

<https://www.epa.gov/ust/field-constructed-tanks-and-airport-hydrant-systems-2015-requirements>

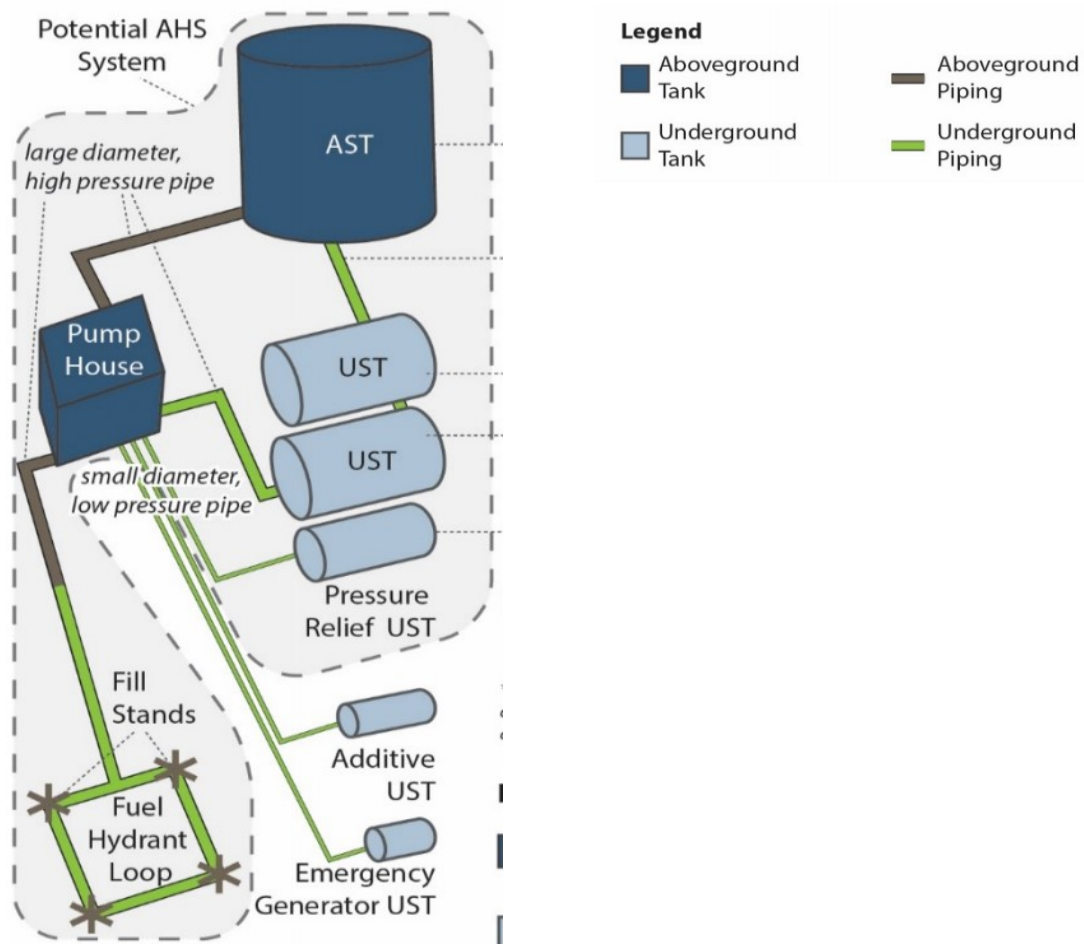

Underground Storage Tank Closure

Temporary Closure

If an UST is taken out of service for three months or more, the owner or operator must follow temporary closure requirements. Owners or operators of USTs in temporary closure must continue to meet leak detection requirements and cathodic protection standards (if applicable), ensure vent lines remain open, and secure product piping, pumps, access manways, and ancillary equipment.

Permanent Closure

UST systems taken out of service for longer than 12 months must be permanently closed unless owners or operators adhere to temporary closure requirements.

Owners and operators of substandard USTS must permanently close at the end of this 12 month period, unless the DENR provides an extension.

All USTs taken out of service permanently must be emptied and either removed from the ground or filled with an inert solid material.

At least 30 days before permanent closure, the owner or operator shall notify the DENR and employ the services of a certified environmental consultant. The environmental consultant must oversee removal of the UST and assess the excavation area for leaks. A Regulated Storage Tank Removal Notification Form is shown on page 47.

Any UST which has been permanently closed may not be brought into use for the storage of regulated substances unless the tank is upgraded to meet new tank standards for design, installation, and release detection. Permanently closed USTs may not be reused for the storage of food or potable water and may not be reused as an aboveground regulated substance storage tank system.



Regulated Storage Tank Removal Notification Form

GENERAL INFORMATION

STATE USE ONLY

If an UST system is taken out of service for longer than 12 months and if an AST system taken out of service for longer than 24 months, it shall be permanently closed. State and Federal laws require notification at least 30 days before permanent closure. If more than five (5) tanks are owned at this location, photocopy this form, and staple the photocopy to the original form.

Where To Notify? Send completed forms to:
Ground Water Quality Program, Storage Tank Section
523 East Capitol, Pierre, SD 57501
Phone # (605) 773-3296, Fax # (605) 773-6035
denr.sd.gov/tanks

FACILITY ID NUMBER: _____

DATE RECEIVED: _____

A. Date Entered into Computer _____

B. Data Entry Clerk Initials _____

C. Date Faxed to PRCF _____

I. OWNERSHIP OF TANK(S)

II. LOCATION OF TANK(S)

Owner Name (Corporation, Individual, Public Agency, or Other Entity) _____

If known, give the geographic location of tanks by degrees, minutes, and seconds.
Examples Lat. 42, 36, 12 N Long. 85, 24, 17 W

Latitude _____ Longitude _____

Street Address _____

Facility Name _____

(if same as Section I, mark box here)

Street Address _____

City _____

State _____

Zip Code _____

County _____

City _____

State _____

Zip Code _____

Phone Number (include Area Code) _____

County _____

Phone Number (include Area Code) _____

Tank Identification Number

Tank No. 1

Tank No. 2

Tank No. 3

Tank No. 4

Tank No. 5

UST (underground) or AST (aboveground) Tank

Capacity _____

Date Last Use _____

Type of Fuel Stored _____

Will this tank system be replaced ? If yes, Describe

Have plans been approved by DENR

Scheduled removal date

Has pre-removal assessment been performed ?

Date performed

Name of Environmental Consultant to be present during removal _____

Name of State or Local Official to be Present _____

Volume of tank bottoms _____ **Volume of Product** _____ **Volume of Water** _____

(sludge)

Disposal of tank, tank bottoms, and water _____

Note: Wastes must be appropriately identified, determine if they exhibit hazardous characteristics and be disposed of properly. Tanks not recycled or salvaged must also be disposed of properly. Receipts or waste manifests may be required by the DENR Waste Management Program upon disposal. Please call (605) 773-3153 for questions regarding the waste disposal.

Form completed by _____ **Date** _____